



Home Generator Systems

Installation & Start-Up Manual



Home Generator System



Thank you for purchasing this quality-built Briggs & Stratton home generator. We're pleased that you've placed your confidence in the Briggs & Stratton brand. When operated and maintained according to the instructions in the operator's manual, your home generator will provide many years of dependable service.

This manual contains safety information to make you aware of the hazards and risks associated with residential generator systems and how to avoid them. This generator system is designed and intended only for use as an optional home standby system that provides an alternate source of electric power and to serve loads such as heating, refrigeration systems, and communication systems that, when stopped during any power outage, could cause discomfort or inconvenience. **Save these instructions for future reference.**

This generator system requires professional installation before use. The installer should follow the instructions completely.

Where to Find Us

You never have to look far to find support and service for your generator. Consult your Yellow Pages. There are many Briggs & Stratton authorized service dealers worldwide who provide quality service. You can also contact Technical Service by phone at **(800) 743-4115**, or click on Find a Dealer at BRIGGSandSTRATTON.COM, which provides a list of authorized dealers.

For Future Reference

Please fill out the information below and keep with your receipt to assist in unit identification for future purchase issues.

Date of Purchase

Generator

Model Number
Model Revision
Serial Number

Engine

Model Number
Serial Number

Briggs & Stratton Power Products Group, LLC
P.O. Box 702
Milwaukee, WI 53201-0702

Copyright © 2010. All rights reserved. No part of this material may be reproduced or transmitted in any form without the express written permission of Briggs & Stratton Power Products Group, LLC.

Table of Contents

Important Safety Instructions	4
Installation	7
Installing Dealer/Contractor Responsibilities	7
Delivery Inspection	7
The Gaseous Fuel System	10
Fuel Consumption	12
Fuel Pipe Sizing	12
System Connectors	13
Grounding the Generator	14
Transfer Switch Communication	14
System Control Panel	15
Final Installation Considerations	15
Initial Start-up (No Load)	16
Engine Adjustment	16
Test Shutdown(s) Procedure	17
Fuel Conversion	19
Schematic (12kW)	20
Wiring Diagram (12kW)	21
Schematic (15kW)	22
Wiring Diagram (15kW)	23
Controls	24
Operation	24
Automatic Operation Sequence	24
Setting Exercise Timer	24
Installation Inspection	24

Not for
Reproduction

Save These Instructions

Important Safety Instructions

SAVE THESE INSTRUCTIONS - This manual contains important instructions that should be followed during installation and maintenance of the generator and batteries.

Safety Symbols and Meanings



Explosion



Fire



Electrical Shock



Toxic Fumes



Rotating Parts



Hot Surface



Auto Start



Explosive Pressure



Chemical Burn



Lift Hazard



Read Manual

▲ The safety alert symbol indicates a potential personal injury hazard. A signal word (DANGER, WARNING, or CAUTION) is used with the alert symbol to designate a degree or level of hazard seriousness. A safety symbol may be used to represent the type of hazard. The signal word NOTICE is used to address practices not related to personal injury.

▲ DANGER indicates a hazard which, if not avoided, *will* result in death or serious injury.

▲ WARNING indicates a hazard which, if not avoided, *could* result in death or serious injury.

▲ CAUTION indicates a hazard which, if not avoided, *could* result in minor or moderate injury.

NOTICE addresses practices not related to personal injury.

The manufacturer cannot possibly anticipate every possible circumstance that might involve a hazard. The warnings in this manual, and the tags and decals affixed to the unit are, therefore, not all-inclusive. If you use a procedure, work method or operating technique that the manufacturer does not specifically recommend, you must satisfy yourself that it is safe for you and others. You must also make sure that the procedure, work method or operating technique that you choose does not render the generator system unsafe.

▲ WARNING Running engine gives off carbon monoxide, an odorless, colorless, poison gas.



Breathing carbon monoxide can cause headache, fatigue, dizziness, vomiting, confusion, seizures, nausea, fainting or death.

- Operate generator **ONLY** outdoors.
- Install a battery operated carbon monoxide alarm near the bedrooms.
- Keep exhaust gas from entering a confined area through windows, doors, ventilation intakes, or other openings.

▲ WARNING The engine exhaust from this product contains chemicals known to the State of California to cause cancer, birth defects, or other reproductive harm.

▲ WARNING Certain components in this product and related accessories contain chemicals known to the State of California to cause cancer, birth defects, or other reproductive harm. *Wash hands after handling.*

▲ WARNING Storage batteries give off explosive hydrogen gas during recharging. Slightest spark will ignite hydrogen and cause explosion. Battery electrolyte fluid contains acid and is extremely caustic.



Contact with battery contents will cause severe chemical burns. A battery presents a risk of electrical shock and high short circuit current.

- DO NOT dispose of battery in a fire. Recycle battery.
- DO NOT allow any open flame, spark, heat, or lit cigarette during and for several minutes after charging a battery.
- DO NOT open or mutilate the battery.
- Wear protective goggles, rubber apron, rubber boots and rubber gloves.
- Remove watches, rings, or other metal objects.
- Use tools having insulated handles.

 **WARNING** Generator produces hazardous voltage. Failure to properly ground generator can result in electrocution.

Failure to isolate generator from power utility can result in death or injury to electric utility workers due to backfeed of electrical energy.

- When using generator for backup power, notify utility company.
- DO NOT touch bare wires or bare receptacles.
- DO NOT use generator with electrical cords which are worn, frayed, bare or otherwise damaged.
- DO NOT handle generator or electrical cords while standing in water, while barefoot, or while hands or feet are wet.
- If you must work around a unit while it is operating, stand on an insulated dry surface to reduce the risk of a shock hazard.
- DO NOT allow unqualified persons or children to operate or service generator.
- In case of an accident caused by electrical shock, immediately shut down the source of electrical power and contact the local authorities. **Avoid direct contact with the victim.**
- Despite the safe design of the residential generator, operating this equipment imprudently, neglecting its maintenance or being careless can cause possible injury or death.
- Remain alert at all times while working on this equipment. Never work on the equipment when you are physically or mentally fatigued.
- Before performing any maintenance on the generator, disconnect the battery cable indicated by a **NEGATIVE, NEG** or (-) first. When finished, reconnect that cable last.
- After your system is installed, the generator may crank and start without warning any time there is a power failure. To prevent possible injury, always set the generator's system switch to **OFF**, remove the service disconnect from the disconnect box AND remove the 15 Amp fuse BEFORE working on the equipment.

 **WARNING** Propane and Natural Gas are extremely flammable and explosive.

Fire or explosion can cause severe burns or death.

- Install the fuel supply system according to NFPA 37 and other applicable fuel-gas codes.
- Before placing the generator into service, the fuel system lines must be properly purged and leak tested.
- After the generator is installed, you should inspect the fuel system periodically.
- NO leakage is permitted.
- DO NOT operate engine if smell of fuel is present or other explosive conditions exist.
- DO NOT smoke around the generator. Wipe up any oil spills immediately. Ensure that no combustible materials are left in the generator compartment. Keep the area near the generator clean and free of debris.

 **WARNING** Hazardous Voltage - Contact with power lines can cause electric shock or burn. Lifting Hazard / Heavy Object - Can cause muscle strain or back injury.

- If lifting or hoisting equipment is used, DO NOT contact any power lines.
- DO NOT lift or move generator without assistance.
- Use lifting pipes as described in *Lifting the Generator*. The unit may shift on the lifting pipes during movement, which can cause injury.
- DO NOT lift unit by roof as damage to generator will occur.

 **WARNING** Starter and other rotating parts can entangle hands, hair, clothing, or accessories.

- NEVER operate generator without protective housings, covers, or guards in place.
- DO NOT wear loose clothing, jewelry or anything that may be caught in the starter or other rotating parts.
- Tie up long hair and remove jewelry.
- Before servicing, remove 15 Amp fuse from control panel and disconnect **Negative (NEG or -)** battery cable.

▲ WARNING Contact with muffler area can result in serious burns. Exhaust heat/gases can ignite combustibles or structures causing a fire.



- DO NOT touch hot parts and AVOID hot exhaust gases.
- Allow equipment to cool before touching.
- DO NOT install the generator closer than 5 feet (1.5m) from any combustibles or structures with combustible walls having a fire resistance rating of less than 1 hour.
- Keep at least minimum distances shown in *General Location Guidelines* to insure for proper generator cooling and maintenance clearances.
- It is a violation of California Public Resource Code, Section 4442, to use or operate the engine on any forest-covered, brush-covered, or grass-covered land unless the exhaust system is equipped with a spark arrester, as defined in Section 4442, maintained in effective working order. Other states or federal jurisdictions may have similar laws. Contact the original equipment manufacturer, retailer, or dealer to obtain a spark arrester designed for the exhaust system installed on this engine.
- Replacement parts must be the same and installed in the same position as the original parts.

▲ CAUTION Installing the 15A fuse could cause the engine to start.



- Observe that the 15 Amp fuse has been removed from the control panel for shipping.
- DO NOT install this fuse until all plumbing and wiring has been completed and inspected.

▲ CAUTION Excessively high operating speeds increase risk of injury and damage to generator. Excessively low speeds impose a heavy load on generator.

- DO NOT tamper with governed speed. Generator supplies correct rated frequency and voltage when running at governed speed.
- DO NOT modify generator in any way.

NOTICE Exceeding generators wattage/amperage capacity can damage generator and/or electrical devices connected to it.

- Start generator and let engine stabilize before connecting electrical loads.

NOTICE Improper treatment of generator can damage it and shorten its life.

- Use generator only for intended uses.
- If you have questions about intended use, contact your authorized dealer.
- Operate generator only on level surfaces.
- Adequate, unobstructed flow of cooling and ventilating air is critical to correct generator operation.
- The access panels/doors must be installed whenever the unit is running.
- DO NOT expose generator to excessive moisture, dust, dirt, or corrosive vapors.
- Remain alert at all times while working on this equipment. Never work on the equipment when you are physically or mentally fatigued.
- DO NOT start engine with air cleaner or air cleaner cover removed.
- DO NOT insert any objects through cooling slots.
- DO NOT use the generator or any of its parts as a step. Stepping on the unit can cause stress and break parts. This may result in dangerous operating conditions from leaking exhaust gases, fuel leakage, oil leakage, etc.
- If connected devices overheat, turn them off and disconnect them from generator.
- Shut off generator if
 - electrical output is lost;
 - equipment sparks, smokes, or emits flames;
 - unit vibrates excessively.

Installation

Equipment Description

This product is intended for use as an optional residential generator system which provides an alternate source of electric power and to serve loads such as heating, refrigeration systems, and communication systems that, when stopped during any power outage, could cause discomfort or inconvenience. This product does not qualify for emergency standby as defined by NFPA 70 (NEC).

Every effort has been made to ensure that information in this manual is accurate and current. However, we reserve the right to change, alter, or otherwise improve the product and this document at any time without prior notice.

Only current licensed electrical and plumbing professionals should attempt home generator system installations. Installations must strictly comply with all applicable codes, industry standards and regulations.

Home Owner Responsibilities

- Read and follow the instructions given in the operator's manual.
- Follow a regular schedule in maintaining, caring for and using your home generator, as specified in the operator's manual.

If you have questions about intended use, ask your installer or dealer or call **(800) 743-4115** between 8:00 AM and 5:00 PM CT.

Installing Dealer/Contractor Responsibilities

- Read and observe the safety rules.
- Install only an UL approved transfer switch that is compatible with the generator.
- Read and follow the instructions given in this installation and start-up manual.

If operating the generator below 40° F (5° C), it is HIGHLY RECOMMENDED that a Model 6030 Cold Weather Kit (includes oil warmer and battery warmer) and a Model 6174 Cold Weather Breather Kit (includes engine duct) be installed. These items are available at your local servicing dealer.

Unpacking Precautions

The unit is shipped bolted to its mounting pad, ready for installation. Avoid damage from dropping, bumping, collision, etc. Store and unpack carton with the proper side up, as noted on the shipping carton.

Delivery Inspection

After removing the carton, carefully inspect the home generator for any damage that may have occurred during shipment.

If loss or damage is noted at time of delivery, have the person(s) making delivery note all damage on the freight bill and affix his signature under the consignor's memo of loss or damage. If loss or damage is noted after delivery, separate the damaged materials and contact the carrier for claim procedures. Missing or damaged parts are not warranted.

Shipment Contents

The generator is supplied with:

- Pre-attached mounting pad
- Fully-serviced oil/lubricating system
- Flexible fuel hook-up hose
- Installation and start-up manual
- Operator's manual
- Engine operator's manual
- Installation checklist
- Spare access door keys
- Spare 15 Amp ATO-type fuse
- Two-pin control panel connector
- Ten-pin control panel connector
- Touch up paint
- Remote LED indicator kit (LED/plate/screws)

Not Included:

- Starting battery (see page 15)
- Connecting wire and conduit
- Fuel supply valves/plumbing
- Crane, lifting straps, chains or cables
- Two 48" lengths of 1" pipe (NOT conduit)
- Hole punches for 16ga steel
- Torque screwdriver, 5 to 50 inch-pound range
- Voltage/frequency meter
- Various special tools and equipment

Generator Placement

Before installing the generator, consult with the homeowner and convey the following guidelines, which may affect the desired installation location.

- ⚠ WARNING** Running engine gives off carbon monoxide, an odorless, colorless, poison gas. Breathing carbon monoxide can cause headache, fatigue, dizziness, vomiting, confusion, seizures, nausea, fainting or death.
- 
- Operate generator **ONLY** outdoors.
 - Install a battery operated carbon monoxide alarm near the bedrooms.
 - Keep exhaust gas from entering a confined area through windows, doors, ventilation intakes, or other openings.

- ⚠ WARNING** Exhaust heat/gases can ignite combustibles or structures causing a fire.
- 
- **DO NOT** install the generator closer than 5 feet (1.5m) from any combustibles or structures with combustible walls having a fire resistance rating of less than 1 hour.

Install generator outdoors in an area which will not accumulate deadly exhaust gas. **DO NOT** install generator where exhaust gas could accumulate and enter inside or be drawn into a potentially occupied building. Ensure exhaust gas is kept away from windows, doors, ventilation intakes or other openings that can allow exhaust gas to collect in a confined area. Prevailing winds and air currents should be taken into consideration when positioning generator.

General Location Guidelines

- Install the unit outdoors **ONLY**.
- Place the unit in a prepared location that is flat and has provisions for water drainage.
- Install the unit in a location where sump pump discharge, rain gutter down spouts, roof run-off, landscape irrigation, or water sprinklers will not flood the unit or spray the enclosure and enter any air inlet or outlet openings.
- Install the unit where it will not affect or obstruct any services (including covered, concealed and underground), such as telephone, electric, fuel, irrigation, air conditioning, and so forth.
- Install the unit where air inlet and outlet openings will not become obstructed by leaves, grass, snow, etc. If prevailing winds will cause blowing or drifting, you may need to construct a windbreak to protect the unit.

- Install the generator as close as possible to the transfer switch and fuel supply to reduce the length of wiring, conduit, and piping.

Laws or local codes may regulate the distance to the fuel supply.

The minimum (**MIN**) clearances from aerial view of generator (**B**) to combustible (**D**), and non-combustible (**A**) materials is shown below.

- These distances are provided to give generator location guidance relative **ONLY** to combustibles, generator cooling, and maintenance.
- The minimum distances in the figure are as shown. All four sides of the generator cannot be enclosed or restricted, even if the minimum distances are maintained. **DO NOT** connect (**A**) and/or (**D**) to (**E**)
- A roof cannot be used.
- Exhaust (**C**) must not be allowed to accumulate.

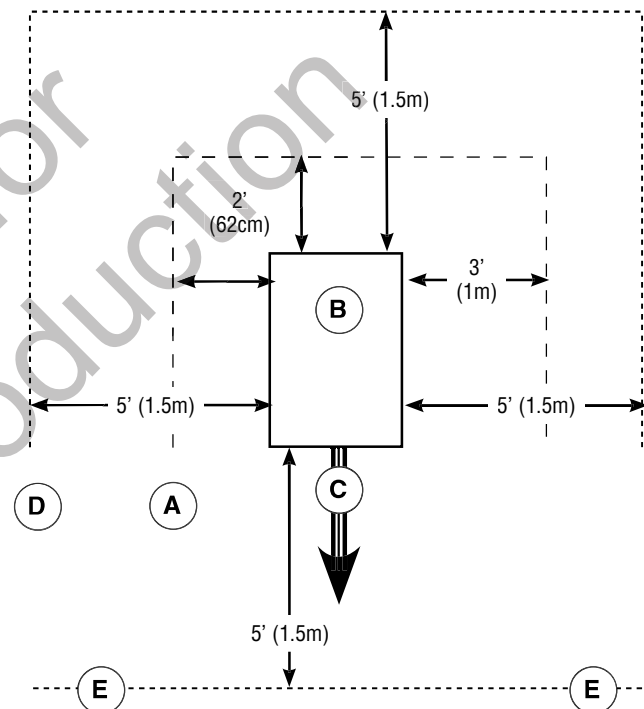

A Non-Combustible material with Fire Resistant Rating of 1 hour or greater

B Home Standby Generator

C Engine Exhaust

D Combustible Material or Structure with a Fire Resistance Rating of less than 1 hour.

E Any structure or material. DO NOT connect (A) and/or (D) to (E).

The generator is shipped already attached to its mounting pad. Unless mandated by local code, a concrete slab is not required.

If mandated by local code, construct a concrete slab at least 3 inches thick and 6 inches longer and wider than the unit. Attach unit to slab with 1/4" diameter (minimum) masonry anchor bolts long enough to retain the unit.

Electrical and Fuel Inlet Locations

The 3/4 inch N.P.T. fuel inlet connector (B) and electrical inlet location (A) is shown:

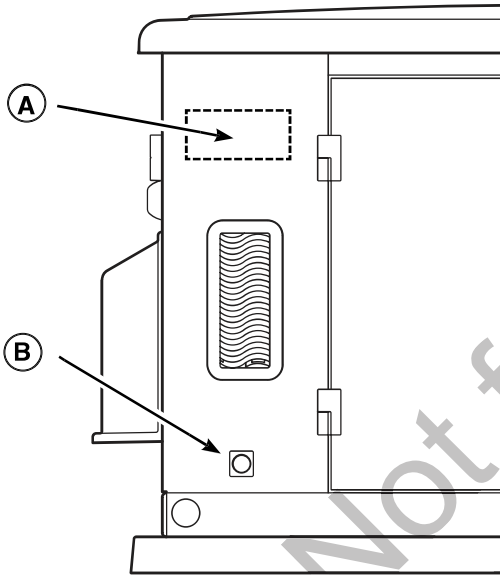

Lifting the Generator

The generator weighs more than 530 pounds (240 kg). Proper tools, equipment and qualified personnel should be used in all phases of handling and moving the generator.

▲ WARNING Hazardous Voltage - Contact with power lines can cause electric shock or burn.
Lifting Hazard / Heavy Object - Can cause muscle strain or back injury.

- If lifting or hoisting equipment is used, DO NOT contact any power lines.
- DO NOT lift or move generator without assistance.
- Use lifting pipes as described in *Lifting the Generator*. The unit may shift on the lifting pipes during movement, which can cause injury.
- DO NOT lift unit by roof as damage to generator will occur.

Two 48" lengths of 1" pipe (C), supplied by the installer, are required to lift the generator manually. Insert pipes through the lifting holes (D) located near the unit's base.

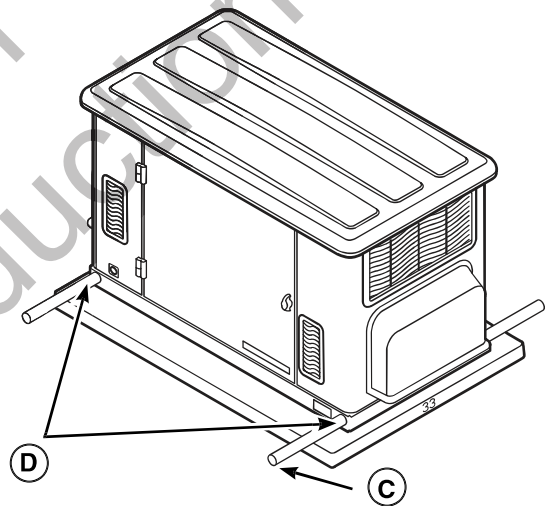

You may also lift the unit using a "hook and hoist" method attached to the lifting pipes, provided that you use a spreader bar to ensure that the chains or cables DO NOT touch the generator's roof.

After unit is in place, fill the lifting holes with the supplied lifting hole plugs. Retouch any chipped paint with supplied touch-up paint.

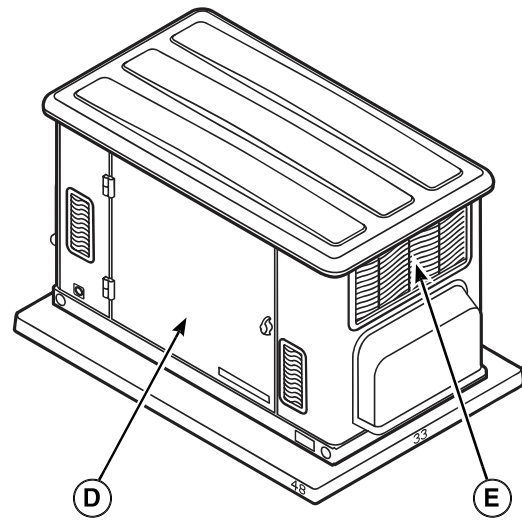
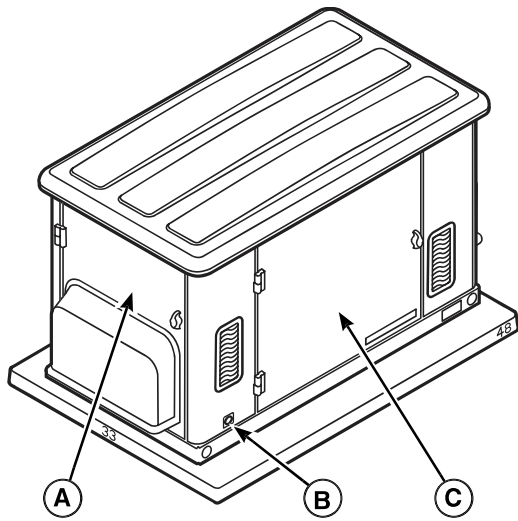

Access Ports

The generator is equipped with an enclosure that has several access doors, as shown. The doors are named for a significant component located behind them, as follows::

- A Control Panel door
- B Fuel Inlet Port (shown for reference)
- C Oil Drain door
- D Oil Fill door
- E Exhaust Port (shown for reference)

▲ WARNING Contact with muffler and engine parts can result in serious burns.



- DO NOT touch hot parts and AVOID hot exhaust gases.
- Allow equipment to cool before touching.

The access doors must be installed whenever the unit is running to assure proper cooling, reduce noise and for added safety.

Each generator is shipped with a set of identical keys. These keys fit the locks that secure the access ports.

To open access door:

1. Insert key into lock of access door handle and turn key one quarter turn counterclockwise.
2. Grasp door's handle and turn one quarter turn counterclockwise to open. Remove key.

To close access door:

1. Close door and turn door's handle one quarter turn clockwise.
2. Insert key into lock of door handle and turn key one quarter turn clockwise. Remove key.

The Gaseous Fuel System

The information below is provided to assist gaseous fuel system technicians in planning installations. In no way should this information be interpreted to conflict with applicable fuel gas codes. Consult with your local fuel supplier or Fire Marshall if questions or problems arise.

▲ WARNING Propane and Natural Gas are extremely flammable and explosive. Fire or explosion can cause severe burns or death.



- LP gas is heavier than air and will settle in low areas.
- Natural gas is lighter than air and will collect in high areas.
- The slightest spark can ignite these fuels and cause an explosion.
- DO NOT light a cigarette or smoke.

TO THE INSTALLER: Consult with the generator owner(s) and convey any technical considerations that might affect their installation plans before applying these general guidelines.

The following general rules apply to gaseous fuel system piping:

- The piping should be of a material that conforms to federal and local codes, rigidly mounted and protected against vibration.
- Piping should be protected from physical damage where it passes through flower beds, shrub beds, and other cultivated areas where damage could occur.
- Install the flexible, gaseous hose (supplied) between the generator fuel inlet port and rigid piping to prevent thermal expansion or contraction from causing excessive stress on the piping material.

⚠ CAUTION The supplied flexible gaseous pipe is not to be installed underground or in contact with the ground.

- The entire flexible gaseous pipe must be visible for periodic inspection and must not be concealed within nor contact nor run through any wall, floor, or partition.

Where local conditions include earthquake, tornado, unstable ground, or flood hazards, special consideration shall be given to increase strength and flexibility of piping supports and connections.

- Piping must be of the correct size to maintain the required supply pressures and volume flow under varying generator load conditions with all gas appliances connected to the fuel system turned on and operating.

⚠ WARNING Propane and Natural Gas are extremely flammable and explosive. Fire or explosion can cause severe burns or death.

- Before placing the generator into service, the fuel system lines must be properly purged and leak tested.
- No leakage is permitted.

- Use a pipe sealant or joint compound approved for use with NG/LPG on all threaded fittings to reduce the possibility of leakage.
- Installed piping must be properly purged and leak tested, in accordance with applicable codes and standards.

Consider the following factors when planning to install the fuel supply system:

- Air density is less at high altitudes, resulting in less available engine power. Specifically, engine power will decrease 3.5% for each 1,000 feet (300 meters) above sea level and 1% for each 10° F (5.6°C) above 77°F (25°C). Make sure you and your installer consider these factors when determining total generator load.
- The generator engine is fitted with a fuel mixer system that meets the specifications of the California Air Resources Board for “tamper-proof” fuel systems.
- A minimum of one accessible, approved manual shutoff valve shall be installed in the fuel supply line within 6 ft (1.8 m) of the generator. A union or flanged connection shall be provided downstream from this valve to permit removal of controls.
- Natural gas fuel supply pressure at the generator’s fuel inlet port should be between 5 to 7 inches of water (in. W.C.) at full load with all gas appliances turned on and operating.
- LP gas fuel supply pressure should be 11 to 14 inches of water (in. W.C.) at full load with all gas appliances turned on and operating.

The generator has been factory set to run on natural gas. If you need to change from natural gas to LP gas, the unit will need to be reconfigured, as described in *Fuel Conversion*.

It is recommended that the fuel connection incorporate the following components:

- A manual fuel shut-off valve located in the interior of the building.
- A manual fuel shut-off valve located outside the building, just before the generator unit.
- Where the formation of hydrates or ice is known to occur, piping should be protected against freezing. The termination of hard piping should include a sediment trap where condensate is not likely to freeze.
- A manometer port should be provided.

The manometer port permits temporary installation of a manometer to ensure that the engine receives the correct fuel pressure to operate efficiently throughout its operating range.

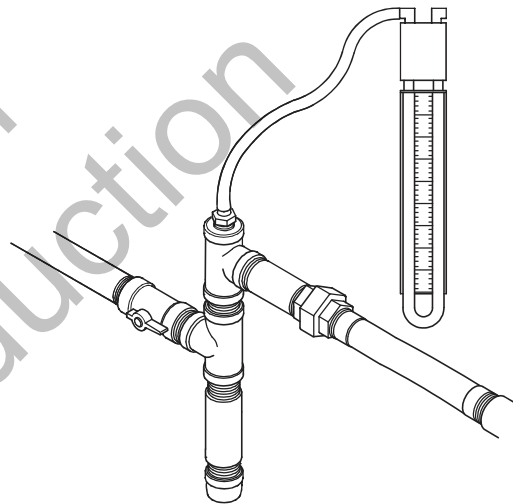

A digital manometer, P/N 19495, is available at your local Briggs & Stratton service center.

When the initial test runs are completed, the manometer is removed and the port is plugged. A typical final fuel connection assembly is shown here, where (A) is the fuel supply and (B) goes to the home generator.

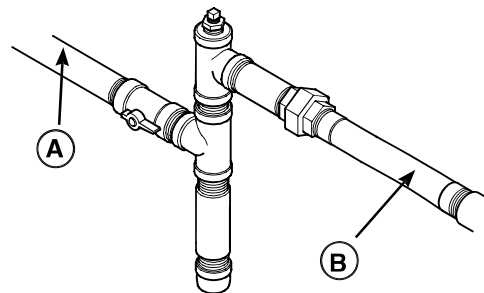

Fuel Consumption

Estimated fuel supply requirements at half and full load for natural gas and LP vapor fuels are shown below.

	Natural Gas		LP Vapor	
	1/2 Load	Full Load	1/2 Load	Full Load
12kW	102 C	195 C	41 C	79 C
	102,000 B	195,000 B	103,000 B	197,000 B
15kW	126 C	242 C	56 C	108 C
	126,000 B	242,000 B	140,000 B	270,000 B

C = Cubic feet per hour
B = BTU's per hour

Fuel Pipe Sizing

The tables below provide the maximum capacity of pipe in cubic feet of gas per hour for gas pressures of 0.5 psi or less and a pressure drop of 0.3 in. water column. Specific gravity of gas is shown.

Listed values compensate for a nominal amount of restriction from bends, fittings, etc. If an unusual number of fittings, bends, or other restrictions are used, please refer to federal and local codes.

NPT	10ft	15ft	20ft	30ft	40ft	50ft	60ft	70ft	80ft	90ft	100ft
3/4"	346	293	240	192	163	145	132	120	113	106	99
1"	653	549	446	360	307	274	250	230	211	197	187

Natural Gas Pipe Size - Gas Flow chart, in cubic feet per hour, specific gravity=0.65

NPT	10ft	15ft	20ft	30ft	40ft	50ft	60ft	70ft	80ft	90ft	100ft
3/4"	277	192	158	126	107	95	87	79	74	69	65
1"	428	360	293	236	202	180	164	151	139	129	123

Liquid Propane (LP) Gas Pipe Size - Gas Flow chart, in cubic feet per hour, specific gravity=1.50

Required Propane Tank Size

The required size of the propane tank at various temperatures when kept at least half full is shown below in the chart. Given the gas withdrawal rate and the lowest average winter temperature, an installer can specify the required LP storage tank size.

Withdrawal Rate	32° F	20° F	10° F	0° F	-10° F	-30° F	-40° F
50 CFH	115	115	115	250	250	400	600
100 CFH	250	250	250	400	500	1000	1500
150 CFH	300	400	500	500	1000	1500	2500
200 CFH	400	500	750	1000	1200	2000	2500
300 CFH	750	1000	1500	2000	2500	4000	5000

Physical Properties	PL Vapor	Natural Gas
Normal Atmospheric State	Gas	Gas
Boiling Point (in °F): Initial End	-44 -44	-259 -259
Heating Value: BTU per gallon (Net LHV*) BTU per gallon (gross**) Cubic feet (gas)	83,340 91,547 2,500	63,310 1,000
Density***	36.39	57.75
Weight†	4.24	2.65
Octane Number: Research Motor	110+ 97	110+

* LHV (Low Heat Value) is the more realistic rating.
** Gross heat value does not consider heat lost in the form of water during combustion.
*** Density is given in "Cubic Feet of Gas per Gallon of Liquid".
† Weight is given in "Pounds per Gallon of Liquid".

System Connectors

Except for the power output and grounding connectors, all signal wire connections are made to removable two- or ten-pin connector plugs. Compare this illustration with your generator to familiarize yourself with the location of these important connections. **Count down to the proper pin location on the control board since visual alignment with the decal can be misleading:**

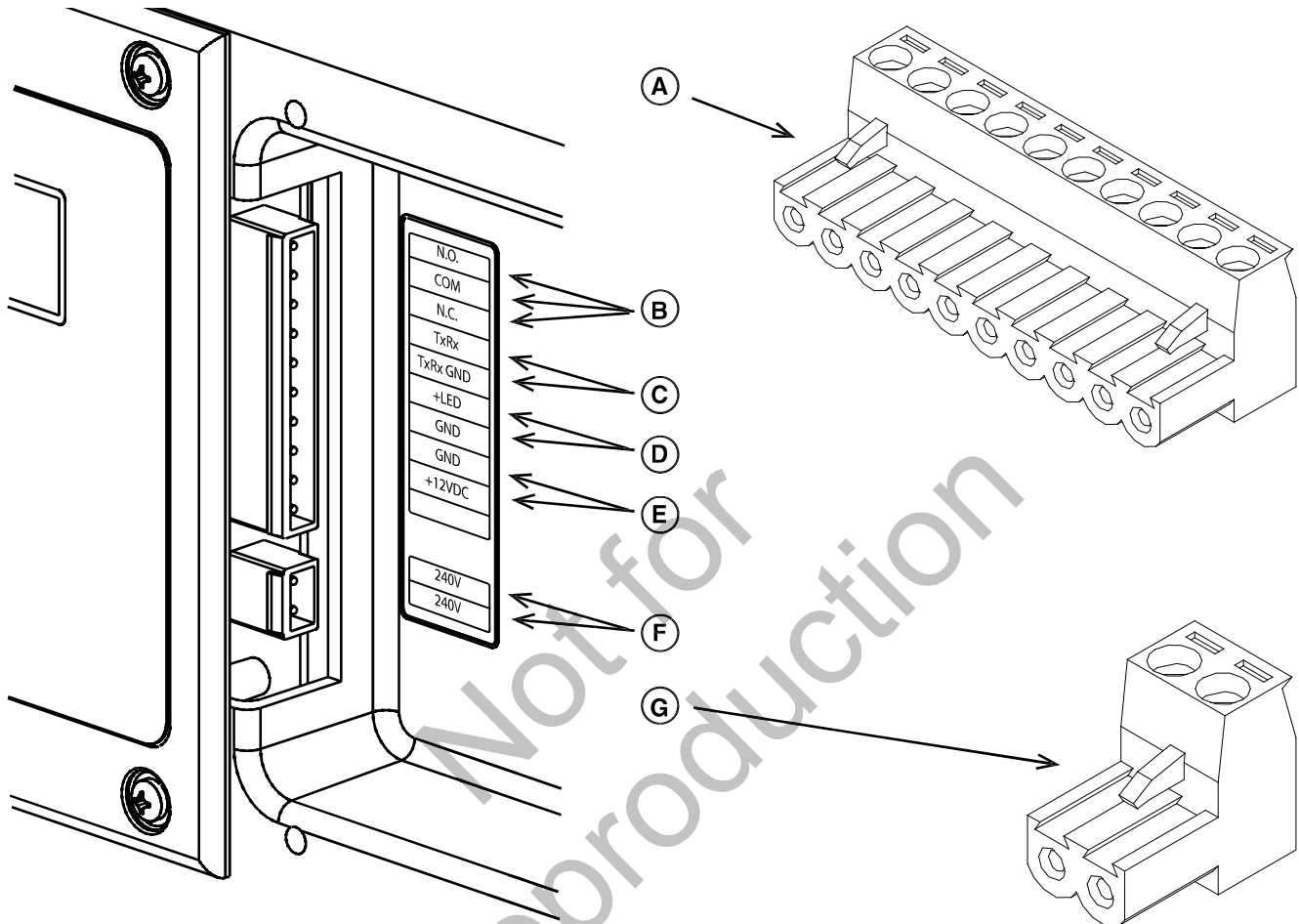

A - Ten-pin Connector Plug

B - Fault Contacts — Use NO, COM and NC to hook up a siren, light, etc. to alert you in case of a fault. Contacts reverse state (NO goes to NC and vice versa) upon a fault condition.

C - Transfer Switch Communication — Connect to transfer switch control board for communication interface using 18AWG copper twisted pair wire.

D - Remote LED Output — Use this to hook up the remote LED supplied with the generator. The remote LED will turn on and off in a series of blinks if certain faults are detected in the generator.

E - +12 Volt DC, .5 Amp Output — Internal power supply.

F - 240 Volt Utility — Use to hook up the 240V utility leads from the transfer switch to the generator.

G - Two-pin Connector Plug

- For 12 kW power output connection, use #8 AWG minimum 300 volt 75°C-90°C copper wire, (ref. NEC Table 310.16, 100 ft. Use National Electric Code for correction factors and wire size calculations.)
- For 15 kW power output connection, use #6 AWG minimum 300 volt 75°C-90°C copper wire, (ref. NEC Table 310.16, 100 ft. Use National Electric Code for correction factors and wire size calculations.)
- For Utility Circuit connection use #14 AWG minimum 300 volt 75°C-90°C copper wire.
- For transfer switch communication use #18 AWG twisted pair conductors, no greater than 200 ft in length, 300 volt 75°C-90°C copper wire.
- When connecting to the ten-pin connector plug, fasten only one wire to each connector screw.
- Torque connector plug screws to 7 in-lb (7.9 Newton meter).

Generator AC Connection System

A single-phase, three-wire AC connection system is used in the home generator. The stator assembly consists of a pair of stationary windings with two leads brought out of each winding. The junction of leads 22 and 33 forms the neutral lead, as shown schematically and as wiring diagram. A complete schematic and wiring diagram can be found later in this manual.

Neutral is not bonded to ground at generator.

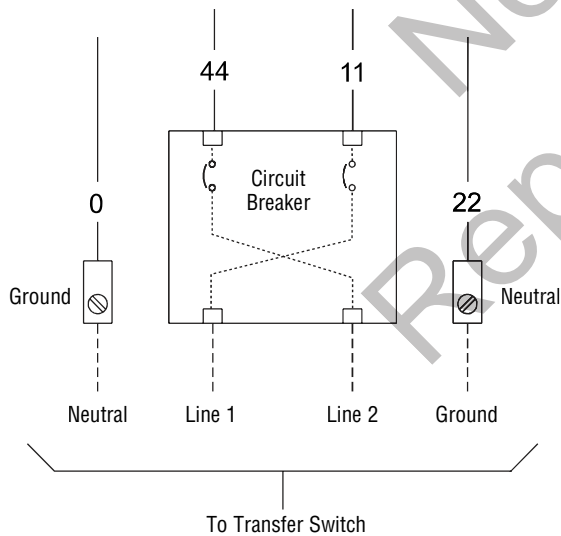
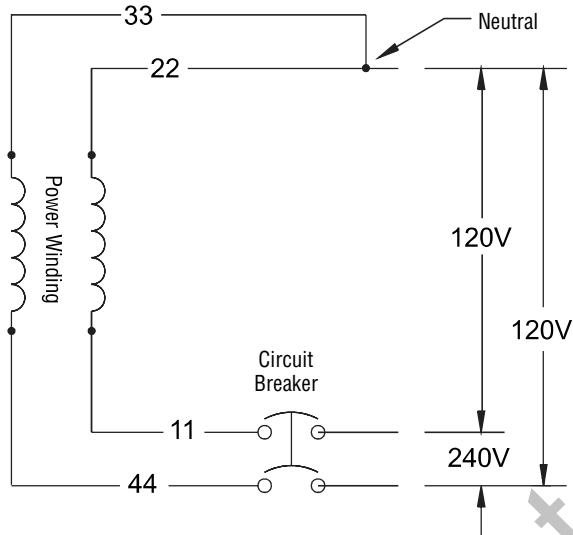

Grounding the Generator

Ground the home generator per applicable codes, standards, and regulations. The generator GND lug is located inside the control panel door under the circuit breaker cover.

Utility Circuit Connection

"240V Utility" leads must be routed in conduit. The "240V Utility" leads deliver power to the generator's circuit board, optional battery warmer and optional oil warmer. This power also charges the battery. When power on these leads is lost, the generator will start.

Using provided 2 pin connector plug and installer-supplied minimum 300V, 14 AWG copper wire, connect each control circuit terminal in the generator to the two-amp fuse terminals in the automatic transfer switch.

When making connections, obey wire type and torque specifications printed on the circuit breaker and neutral/ground connector.

Transfer Switch Communication

(Units with ACCM II or later transfer switch only)

Using #18 AWG twisted pair conductors, no greater than 200 ft in length, connect Tx Rx and Tx Rx GND from the generator control panel (A) to the GND and T/R on the transfer switch control board (B).

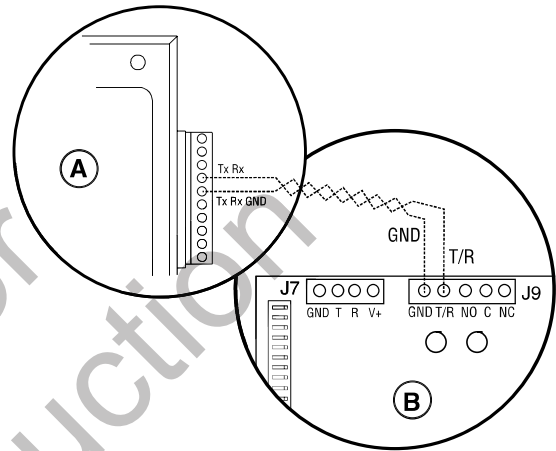

Fault Detection System

The generator may have to run for long periods of time with no operator present. For that reason, the system is equipped with sensors that automatically shut down the generator in the event of potentially damaging conditions, such as low oil pressure, high temperature, over speed, and other conditions. Refer to *Fault Detection System* in the operator's manual for more detailed information.

The owner will use the remote LED indicator to observe the status of the home generator system. The remote LED will turn on and off in a series of blinks if certain faults are detected in the generator system. Consult with the owner for a convenient location. Locate the electrical box in an area visible by the home owner such as near a garage door opener or security control panel.

To install the remote LED indicator:

1. Push the LED through the mounting plate from the front until it snaps in place. The LED is polarity sensitive.
2. Using provided 10 pin connector and installer-supplied minimum 18AWG wire, connect the remote LED to the generator control board +LED and GND connection. Use wire nuts to attach wire to LED leads.
3. Attach mounting plate to installer-supplied electrical box.

System Control Panel

The home generator control panel, located inside the generator housing, is shown below.

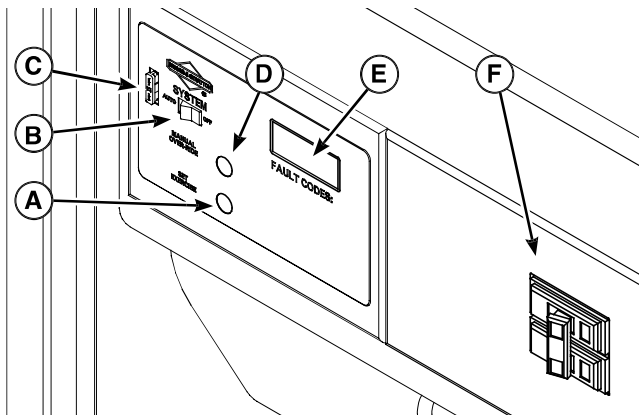

Brief descriptions of the controls used during installation are:

- A - **SET EXERCISE** — Used to set the exercise cycle.
- B - System Switch — Switches modes to **OFF** or **AUTO**.
- C - 15 Amp Fuse — Protects the DC control circuits.
- D - **MANUAL OVER-RIDE** — Turns generator **ON** or **OFF**.
- E - Digital Display — Displays running time and fault codes.
- F - Circuit Breaker — Must be **ON** to supply power to the transfer switch.

More information may be found in *Controls* in the operator's manual.

System Switch

This two-position switch is the most important control on the home generator and is used as follows:

- “**AUTO**” position is the normal operating position. If a utility power outage is sensed, the system will start the generator. When utility power is restored, lets the engine stabilize internal temperatures, shuts off the generator, and waits for the next utility power outage.
- “**OFF**” position turns off running generator, prevents unit from starting and resets any detected faults.

15 Amp Fuse

Protects the home generator DC control circuits. If the fuse has ‘blown’ (melted open) or was removed, the engine cannot crank or start. Replace the fuse using only an identical ATO 15A fuse. One spare fuse is supplied with the unit. If fuse was blown or removed, you will need to reset the exercise timer (see *Setting Exercise Timer*).

Final Installation Considerations

Engine Oil

NOTICE Any attempt to crank or start the engine before it has been properly serviced with the recommended oil will result in equipment failure.

- Refer to *Maintenance* in the operator's manual and engine manual for oil fill information.
- Damage to equipment resulting from failure to follow this instruction will void engine and generator warranty.

The engine is shipped from the factory pre-run and filled with synthetic oil (API SJ/CF 5W-30). This allows for system operation in a wide range of temperature and climate conditions. Before starting the engine, check oil level and ensure that engine is serviced as described in the engine operator's manual.

The use of synthetic oil does not alter the required oil change intervals described in the engine operator's manual.

Battery

The installer must supply and install a valve-regulated rechargeable starting battery. The starting battery **MUST** conform to the specifications shown in this chart.

Battery Specifications	
Volts	12 Volt DC
Amps (MIN)	600 CCA (cold cranking amps)
Type	AGM
Terminal Hardware	M6
Dimensions (MAX):	
Width	5.5 inches (140mm)
Length	9.0 inches (230mm)
Height	8.25 inches (210mm)

Install the battery as described in *Servicing the Battery* in the *Maintenance* section of the operator's manual. Installer must connect battery charge wire (wire #13) to positive battery terminal! Always make sure the **NEGATIVE** cable is connected last.

▲ WARNING Battery posts, terminals and related accessories contain lead and lead compounds - chemicals known to the State of California to cause cancer and reproductive harm. *Wash hands after handling.*

Fuel Supply System

Ensure that all fuel pipe connections are tight, secure and without leaks.

Ensure that all gas line shutoff valves are OPEN and that adequate fuel pressure is available whenever automatic operation is desired.

Initial Start-up (No Load)

Before operating the home generator or placing it into service, inspect the entire installation carefully. Then begin testing the system without any electrical loads connected, as follows:

Unit has been set-up for NG operation at the factory. Fuel conversion, if needed, must be completed prior to performing these steps. See *Fuel Conversion* later in this section.

1. Remove four screws that hold circuit breaker cover to air intake guard.

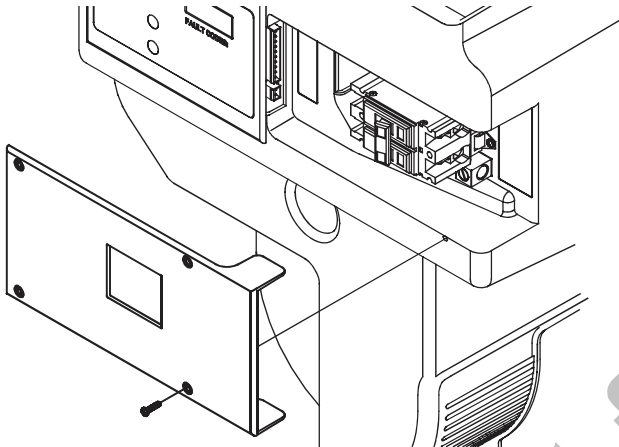

2. Connect an accurate AC voltmeter and a frequency meter to line side of generator's circuit breaker.
3. Set generator's main circuit breaker to **ON** (closed) position.
4. Install 15 Amp fuse in control panel.
5. Set generator's system switch to **AUTO**.
6. Push and hold **MANUAL OVER-RIDE** button on control panel for about six seconds. Engine will start.

When the generator is started for the very first time, it will require that air in the gaseous fuel lines be purged. This may take a few minutes.

7. Listen for unusual noises, vibration or other indications of abnormal operation. Check for oil leaks while engine runs.
8. Let engine warm up for about five minutes to allow internal temperatures to stabilize.
9. Check generator output at load side of circuit breaker. Voltage should be 239-262 Volts, frequency should be 62.0 - 62.5 Hz.

If either parameter is outside these ranges, perform *Engine Adjustment* described later in this section.

10. Check generator output between one generator connection lug and neutral lug, then between other generator connection lug and neutral lug. In both cases, voltage reading should be between 119-131 Volts.

DO NOT proceed until you are certain that generator AC voltage and frequency are correct and within the stated limits. To obtain the proper generator frequency, see *Engine Adjustments*.

11. Push and hold **MANUAL OVER-RIDE** button on control panel again until engine stops.
12. Install circuit breaker enclosure cover.

Engine Adjustment

There are regional variances in the composition of natural gas. Each home generator unit leaves the factory set for NG operation. If the generator output voltage or frequency measured during *Initial Start-Up* is outside the listed ranges, the combustibility of the gas supplied at the installation site may be substantially different from the fuel used at the factory.

To adjust the engine for this difference, proceed as follows.

1. Remove four screws that hold circuit breaker cover to air intake guard.
2. Connect an accurate frequency meter to line side of generator's main circuit breaker.
3. Ensure that the 15 Amp fuse is installed.
4. Set the generator's main circuit breaker **ON**.
5. Set the generator's system switch to **AUTO**.
6. Push **MANUAL OVER-RIDE** button on control panel. When the engine starts, allow it to warm up for five minutes.
- 7A. For a 12kW generator, normal no load frequency is 62.0 to 62.5 Hz. If adjustment is needed at no load, slowly rotate the governor adjustment nut (A) clockwise and/or counterclockwise until frequency is 62.0 to 62.5 Hz.

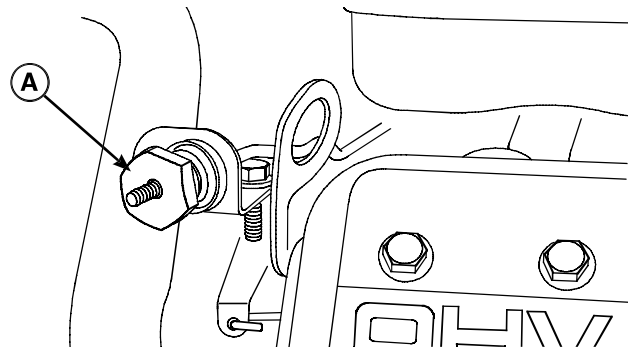

- 7B. For a 15kW generator, normal no load frequency is 62.0 to 62.5 Hz. If adjustment is needed at no load, slowly rotate the governor adjustment screw (B) clockwise and/or counterclockwise until frequency is 62.0 to 62.5 Hz.

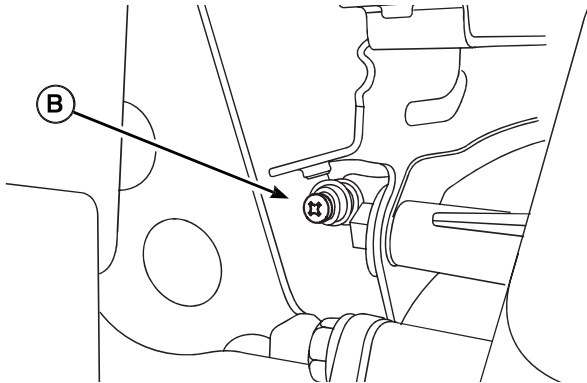

8. Turn service disconnect to transfer switch **OFF**. After a short time delay, transfer switch will connect to generator.
9. Load generator to full load.
10. After load stabilizes, frequency should be above 57.0 Hz.
11. If frequency is below 57.0 Hz, slowly rotate the governor adjustment clockwise and/or counterclockwise until frequency is above 57.0 Hz.
12. Turn service disconnect to transfer switch **ON**. Transfer switch will connect to utility power after five minutes.
13. Push and hold **MANUAL OVER-RIDE** button on control panel until engine stops.
14. After the engine has stopped:
 - If an adjustment was made in step 11, repeat steps 2 through 7.
 - If an adjustment was not made in step 11, proceed to step 15.

If no load frequency falls out of the no load range shown in step 7 after full load adjustment is made, contact an authorized service center.

15. Reinstall circuit breaker cover.

Test Shutdown(s) Procedure

The installer will test the system to verify that diagnostic messages are correctly shown on the system control panel digital display, as follows:

FC_1 - Low Battery

No test procedure required for this fault.

FC_2 - Low Oil Pressure:

Locate wire #85 connected to the oil pressure switch. Shown here is the oil pressure switch (D) and the oil filter location (C) for the 12kW generator:

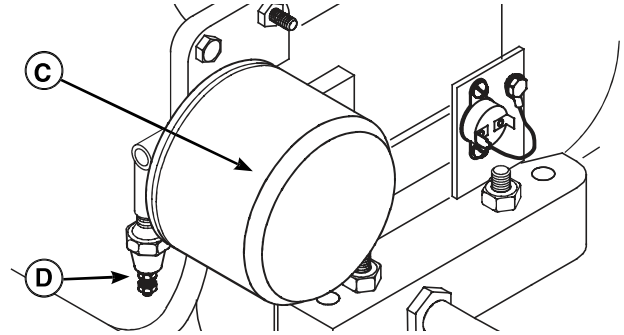

Shown here is the oil pressure switch (D) and the oil filter location (C) for the 15kW generator:

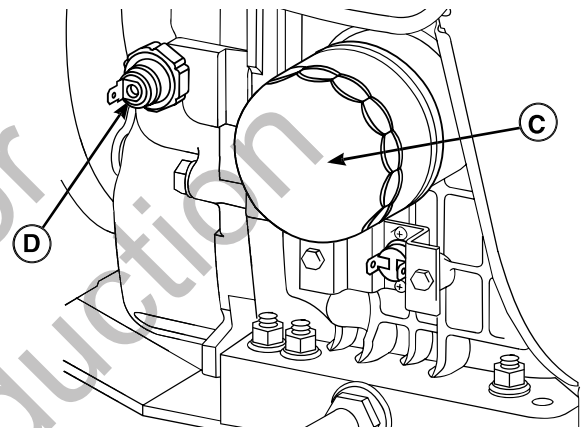

Connect an installer-supplied jumper wire to wire #85. With the system switch in **AUTO** position, push **MANUAL OVER-RIDE** to start the generator. With the generator running, connect other end of jumper to a good ground location such as the engine block. The generator will shut down and FC_2 will be displayed on the system control panel. Remove the jumper wire. Turn the system switch to **OFF** for 30 seconds to clear the fault.

FC_3 - Low Voltage

With the system switch in **AUTO** position, push **MANUAL OVER-RIDE** to start the generator. With the generator running at no load, turn the generator circuit breaker to **OFF**. The generator should shut down and FC_3 will be displayed on the system control panel. Turn the system switch to **OFF** for 30 seconds to clear the fault. Turn the circuit breaker to **ON** position.

FC_4 - Engine Does Not Start

With the generator not running, turn the installer supplied manual fuel valve to the **OFF** position. With the system switch in **AUTO**, turn off utility power. The engine will crank, attempting to start. After approximately a two-minute start attempt (10 seconds of crank, 10 seconds of rest) the generator should terminate the start attempt and FC_4 will be displayed on the system control panel. Turn the system switch to **OFF** for 30 seconds to clear the fault. Turn the installer supplied fuel valve to the **ON** position.

FC_5 - Low Frequency

With the system switch in **AUTO** position, push **MANUAL OVER-RIDE** to start the generator. Locate the governor lever and SLOWLY lower engine speed. Do NOT change engine speed using the governor adjustment. When the generator reaches a speed slower than 55 Hz for three seconds the generator will shut down and FC_5 will be displayed on the system control panel. Turn the system switch to **OFF** for 30 seconds to clear the fault.

FC_6 - Engine Overspeed

With the system switch in **AUTO** position, push **MANUAL OVER-RIDE** to start the generator. Locate the governor lever and SLOWLY raise engine speed. Do NOT change engine speed using the governor adjustment. When the generator output frequency is 65-70 Hz after three seconds the generator will shut down and FC_6 will be displayed on the system control panel. If the generator output frequency is greater than 70 Hz the generator will shut down immediately. Turn the system switch to **OFF** for 30 seconds to clear the fault.

FC_7 - High Temperature

Locate wire #95 connected to the temperature switch. Shown here is the temperature switch (A) and the oil filter location (B) for the 12kW generator:

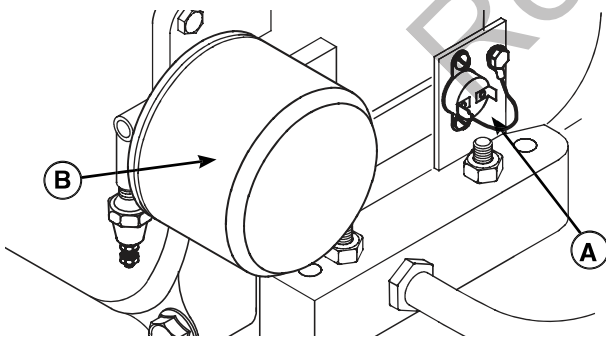

Shown here is the temperature switch (A) and the oil filter location (B) for the 15kW generator:

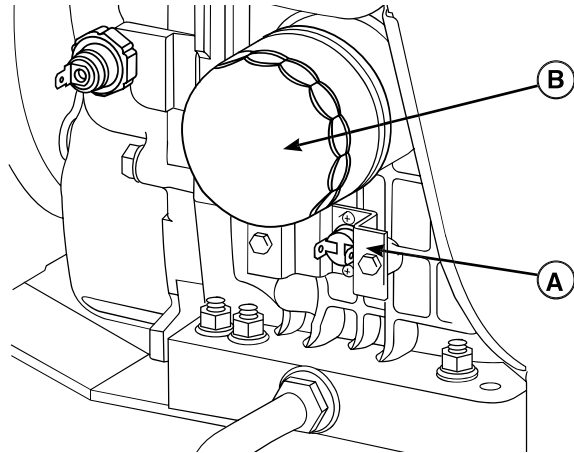

Connect an installer-supplied jumper wire to wire #95. With the system switch in **AUTO** position, push **MANUAL OVER-RIDE** to start the generator. With the generator running, connect other end of jumper to a good ground location such as the engine block. The generator should shut down and display FC_7 on the system control panel. Remove the jumper wire. Turn the system switch to **OFF** for 30 seconds to clear the fault.

FC_8 - Transfer Switch Fault

(Units with ACCM II or later transfer switch only)

Verify that utility power is present at the automatic transfer switch. With the system switch in **AUTO** position, carefully remove one of the 2 Amp fuses from the transfer switch. FC_8 will display on the system control panel. Carefully reinstall the fuse in the transfer switch, then turn the system switch to **OFF** for 30 seconds to clear the fault.

Analyze Test Results

If any test procedure above does not cause the generator to shut down and display the indicated fault, repair the fault condition before putting the unit into service.

Fuel Conversion

The engine of your home generator system is factory calibrated to run on natural gas (NG). It may also be operated on liquefied petroleum (LP) vapor. There is no additional hardware/equipment required to switch between either fuel. However, LP fuel inlet pressure must be between 11 and 14 inches water column.

To configure the 12kW home generator fuel system for LP use:

1. Open control panel and oil fill access doors.
2. Set generator's system switch to **OFF**.
3. Remove 15 Amp fuse from control panel.
4. Connect the fuel select solenoid by joining the two-pin electrical connector (**C**).

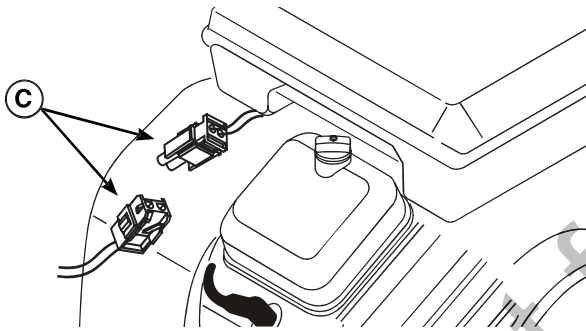

5. Reinstall 15 Amp fuse in control panel.
6. Set generator's system switch to **AUTO**.
7. Close control panel and oil fill access doors.

The system is now ready to operate automatically using LP fuel. With a fixed main jet for LP gas, there is no need to perform any engine adjustments for LP operation.

To configure the 15kW home generator fuel system for LP use:

1. Open control panel and oil fill access doors.
2. Set generator's system switch to **OFF**.
3. Remove 15 Amp fuse from control panel.
4. Remove cap from LP inlet on T-valve (**E**).

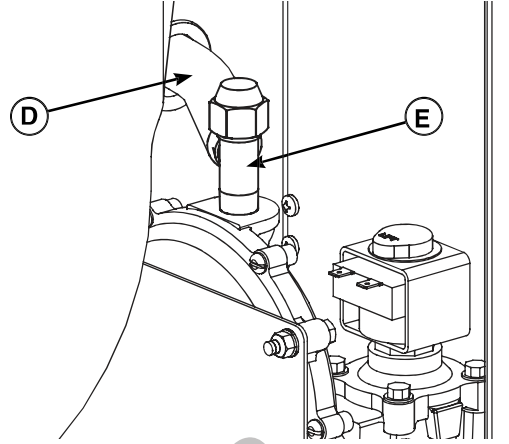

5. Remove fuel line from NG inlet.
6. Place cap from LP inlet onto NG inlet.
7. From oil fill access area, pull fuel line (**D**) out of top hole and route it through bottom hole.

Failure to route fuel line through bottom hole may cause the fuel line to kink. When tightening fuel hose fittings make certain the fuel hose does not twist or kink. If the fuel line kinks, the generator may start but will not operate properly.

8. Connect fuel line (**D**) to T-valve's LP inlet.
9. Reinstall 15 Amp fuse in control panel.
10. Set generator's system switch to **AUTO**.
11. Close control panel and oil fill access doors.

The system is now ready to operate automatically using LP fuel. With a fixed main jet for LP gas, there is no need to perform any engine adjustments for LP operation.

Schematic (12kW)

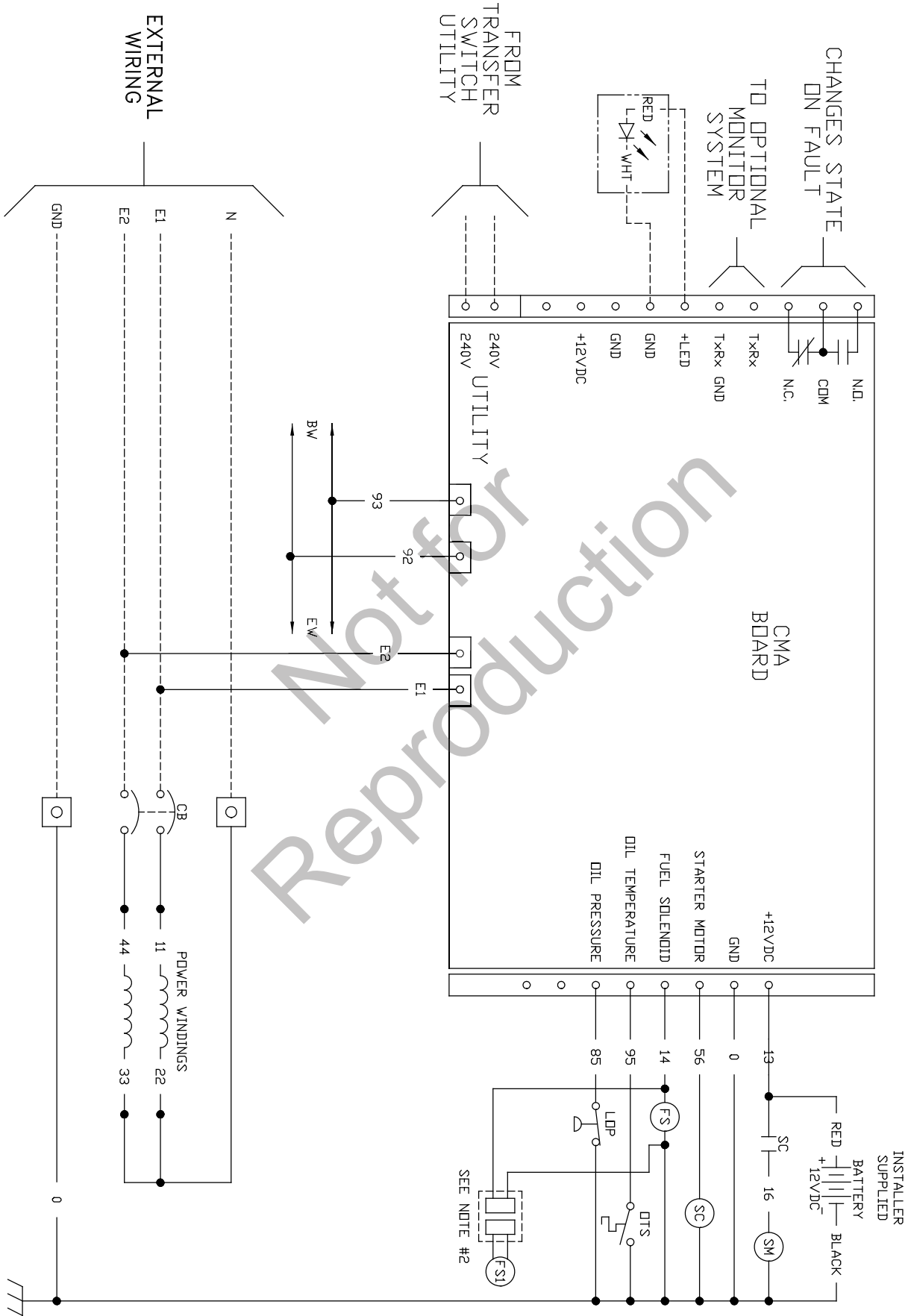

Schematic (15kW)

