



PM0601250.02

Insert
Additif
Adición

ELECTRIC GENERATOR - GROUPE ELECTROGENE - GENERADOR ELECTRICO

Thank you for selecting a Powermate® Generator. The Powermate® generator has been made to supply reliable, portable electrical power when utility power is not available. We hope you will enjoy your new generator. Welcome to our worldwide family of Powermate® generator users.

Merci d'avoir choisi le groupe électrogène Powermate®. Ce groupe électrogène Powermate® a été conçu pour fournir le pouvoir électrique, portatif et fiable quand le pouvoir d'utilité n'est pas disponible. Nous espérons que votre groupe électrogène vous donnera entière satisfaction. Bienvenue dans la famille mondiale des utilisateurs de groupes électrogènes Powermate®.

Gracias por seleccionar un generador Powermate®. El generador Powermate® ha sido diseñado para proporcionar energía eléctrica confiable y portátil cuando no hay servicio disponible de energía pública. Esperamos que disfrute de su nuevo generador. Bienvenido a nuestra familia de usuarios de generadores Powermate® a nivel mundial.



IMPORTANT – Please make certain that persons who are to use this equipment thoroughly read and understand these instructions and any additional instructions provided prior to operation.

IMPORTANT - Prière de vous assurer que les personnes destinées à utiliser cet appareil ont pris soin d'en lire et d'en comprendre le mode d'emploi ou les directives avant de le mettre en marche.

IMPORTANTE. Asegúrese que las personas que utilizarán este equipo lean y entiendan completamente estas instrucciones y cualquier instrucción adicional proporcionada antes del funcionamiento.

**Pramac America, LLC
4970 Airport Road
P. O. Box 6001
Kearney, NE 68847**

**1-800-445-1805
www.powermate.com**

MAJOR GENERATOR FEATURES

- * 22 HP Subaru OHV engine
- * Cast-iron cylinder sleeve
- * Low oil sensor
- * Receptacles on control panel
- * Electric Start
- * Idle control
- * CordKeeper™
- * Digital Hour Meter
- * 8 gallon plastic fuel tank
- * Portability Kit

CONTROL PANEL

A. 120 Volt GFCI Receptacle

Ground Fault Circuit Interrupter duplex receptacle is rated so that a total of 20 amps may be drawn regardless of whether both halves or just one receptacle is used. This receptacle may be used along with other receptacles provided the generator is not overloaded and total power drawn is kept within nameplate ratings.

Ground Fault Circuit Interrupter

(Conforms to U.L 943, Class A and NEC requirements)

This device protects you against hazardous electrical shock that may be caused if your body becomes a path through which electricity travels to reach ground. This could happen when you touch an appliance or cord that is "live" through faulty mechanism, damp or worn insulation, etc.

The GFCI receptacle cannot be reset once tripped, unless the generator is running and power is available to it. Test regularly to assure proper operation.

B. 120/240 V, 30 Ampere Twistlock Receptacle

A maximum of 30 amps may be drawn from the 120/240 volt receptacle. However, current must be limited to the nameplate rating. If the 120/240 volt receptacle is used along with the 120 volt receptacle, the total load drawn must not exceed the nameplate ratings.

C. 120/240 Volt Heavy Duty Receptacle

This receptacle is rated at 50 amps but the current must be limited to the nameplate rating. If this receptacle is used along with the 120 volt receptacles, the total load drawn must not exceed the nameplate ratings.

D. Circuit Protectors

The receptacles are protected by an AC circuit protector. If the generator is overloaded or an external short circuit occurs, the circuit protector will trip. If this occurs, disconnect all electrical loads and try to determine the cause of the problem before attempting to use the generator again. If overloading causes the circuit protector to trip, reduce the load.

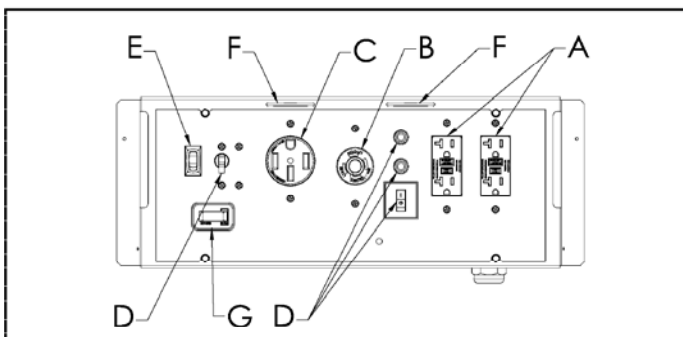

NOTE: Continuous tripping of the circuit protector may cause damage to generator or equipment. The circuit protector may be reset by pushing the button of the protector.

E. Idle Control Switch

The Idle Control circuit is designed to extend engine life and improve fuel usage by slowing the engine down to approximately 2000 RPM in a "No Load" condition. The noise is also greatly reduced during this condition.

When power is required from the generator an electronic control module automatically senses current flow in the electrical outlet and allows the engine to return to full speed or standard operating condition. Likewise, when the load is removed, the generator will automatically return to the idle condition after a 4-5 second delay.

A convenient switch is mounted in the control panel for easy access and will disable the Idle Control circuitry when in the off position.

NOTE: A 12V battery must be installed in order for the idle control to function.

F. CordKeeper™ Restraint

The CordKeeper™ restraint is a unique feature used to prevent plugs from being pulled out of the receptacles.

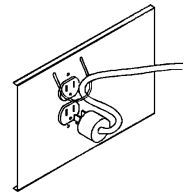

G. Digital Hour Meter

- Press and release mode button to toggle between **Total Timer** and **Timer 1 (TMR1)**.
- **Total Timer** displays and records the total hours your generator has run. **Total Timer** is not resettable.
- **Timer 1** can be used to track operating hours for service intervals. **Timer 1** is resettable by holding the mode button down for 3 seconds while **TMR1** is displayed.

HEAVY DUTY POWER CORD CONNECTION



CAUTION: Insure that the power cord used is well insulated and has a sufficient rating to match that of the plug.

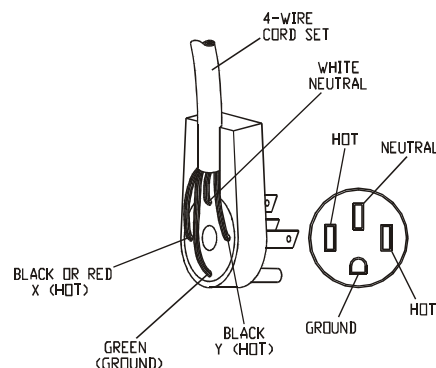

120/240 Volt Heavy Duty Plug

ELECTRIC START WIRING

The generator is equipped with electric start. An "Off-On-Start" rotary key switch is provided on the recoil end panel. All necessary wiring is provided. The battery is provided. See engine manual for wiring diagram (3A Charge Coil), and additional information.

Note that the battery must be connected in order for this engine to run. The 12V fuel solenoid must be engaged in order for fuel to reach the carburetor. This fuel solenoid also helps prevent engine backfire. This engine is not equipped with recoil start.

DC FEATURES

The charging system of the unit is supplied by the starter/alternator of the engine. 12 volts DC is constantly charging the battery when the unit is running. Disconnecting the battery will stop the charging of the battery.

Before charging a storage battery, check the electrolyte fluid level in all the cells. (Sealed batteries do not require checking). Add distilled water to each cell if necessary, to bring the level back up to the manufacturer's required level.

 **WARNING:** Storage batteries give off **EXPLOSIVE** hydrogen gas while charging. Do not allow smoking, open flames, sparks, or spark producing equipment in the area while charging.

 **WARNING:** Battery electrolyte fluid is comprised of sulfuric acid that can be very dangerous and cause severe burns. Do not allow this fluid to contact eyes, skin, clothing, etc. If contact or spillage does occur, flush the area with water immediately.

 **CAUTION:** This battery charging system is intended to recharge weak batteries, not to "boost start" vehicles. Do not overcharge battery or leave battery unattended.

 **CAUTION:** Do not continue to charge a battery that becomes hot or is fully charged.

BATTERY INSTALLATION

Pramac America recommends a 12 V battery with at least 235 cranking amps, Model U1L, Lawn and Garden Battery.

1. Place the battery in the position provided.
2. Place the bolts through the holes on the battery pan.
3. Place the bolts through the loops on the Hold-Down bracket.
4. Place the spacers and washers on the bolts.
5. Tighten down the Hold-Down assembly with the 1/4-20 nuts provided.

Note: Spacers may be removed depending on the battery height.

WARNING: Batteries contain sulfuric acid (when filled). May contain explosive gasses. Always abide by safety warnings provided with the battery.

- Keep sparks, flame and cigarettes away.
- Hydrogen gas is generated during charging and discharging.
- Always shield eyes, protect skin and clothing when working near batteries.

Connect the red 8 ga. battery lead to the positive (+) battery post and the black 8 ga. battery lead to the negative (-) battery post with the bolts and nuts provided.

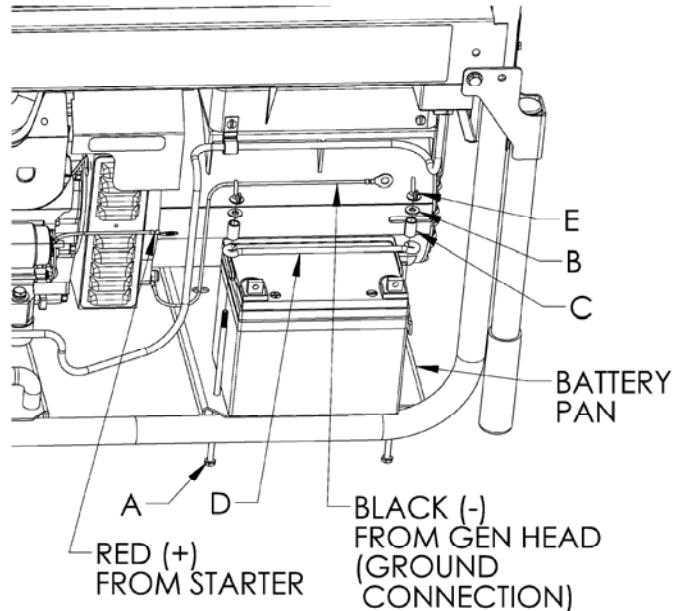

BATTERY KIT PARTS LIST

Item	Description	Qty.
A.	*Bolt, 1/4-20 X 8"	2
B.	*Washer 1/4	2
C.	*Spacer	2
D.	Hold Down bar (P/N 0036525.02)	1
E.	*Wing nut, 1/4-20	2

* These are standard parts available at your local hardware store.

PORTABILITY KIT INSTALLATION

TOOLS REQUIRED: Hammer, 1/2" wrench, ratchet with a 1/2" socket, and wood blocks.
Refer to the drawing for proper alignment of Foot bracket and Wheel brackets.

Refer to the parts list on pages 15 and 16.

Wheel Bracket & Wheel Installation

1. Block up end of generator, about 8" high, opposite the fuel tank cap to install wheels and wheel bracket assy.
2. Add 5/16 washer (item 29) to the 1 3/4" bolts (item 71) and insert bolts/washers through the holes located in the base pan of the carrier.
3. Place the wheel bracket (item 65) through the bolts and add a 5/16 nyloc nut (item 27) and tighten securely. (On the bottom side of the pan in-between the holes will be a 1" square brace, the wheel bracket will set on this brace).
4. Add wheel spacer (item 70) to the axle.
5. Slide the wheel (item 64) onto the axle until it is snug against the spacer. The wheel is on correctly if there is approximately a 1/2" gap between the carrier tubing and the side of the wheel. If it is less then 1/2" from the carrier, turn the wheel over and reinstall. Align the wheels parallel to the carrier tubing and tighten nuts securely. To align correctly, the bolts holding the wheel bracket may have to be loosened.
6. With a hammer, add the plastic cap (item 69) on end of axle.
7. Repeat above instructions for the remaining wheel.

Foot bracket Installation

1. Block up opposite end of the unit, about 8" high.
2. Add 5/16 washer (item 29) to 1" bolts (item 30) and place through holes in the base pan.
3. Add foot bracket assembly (item 66) to bolts, add 5/16 nyloc nuts (item 27) and tighten securely.
4. Repeat above instructions for the remaining foot bracket assembly.

Locking Handle

1. Attach the lanyards (item 72) to the release pins (item 73) and carrier as shown in the illustration.
2. To lock the handle in the extended position, align the holes in the handle brackets with the holes in the carrier brackets and insert the release pins.

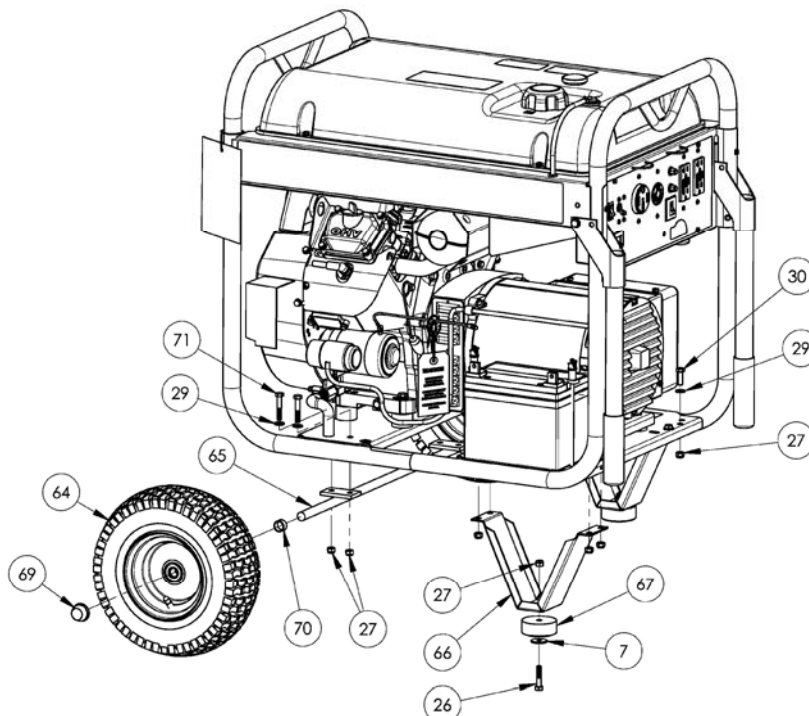
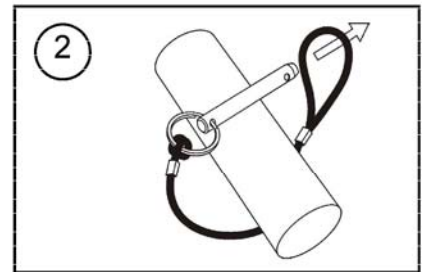
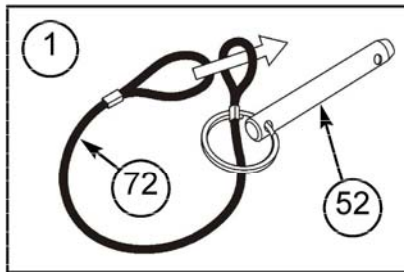

LIMITED WARRANTY

Warranty Coverage: Pramac America, LLC (the Company) warrants to the original retail customer in North America that it will repair or replace, free of charge, any parts found by the Company or its authorized service representative to be defective in material or workmanship. This warranty covers the cost of replacement parts and labor for defects in material or workmanship.

Not Covered:

- Transportation charges for sending the product to the Company or its authorized service representative for warranty service, or for shipping repaired or replacement products back to the customer; these charges must be borne by the customer.
- Engine is covered exclusively by a separate warranty from the engine manufacturer, included with the engine Manual.
- Damages caused by abuse or accident, and the effects of corrosion, erosion and normal wear and tear.
- Warranty is voided if the customer fails to install, maintain and operate the product in accordance with the instructions and recommendations of the Company set forth in the owner's manual.
- The Company will not pay for repairs or adjustments to the product, or for any costs or labor, performed without the Company's prior authorization.

Warranty Period: Three (3) years from the date of purchase on products used solely for consumer applications; if a product is used for business or commercial applications, the warranty period will be limited to one (1) year from the date of purchase; if a product is used for rental applications, the warranty period will be limited to ninety (90) days from the date of purchase. For warranty service, the customer must provide dated proof of purchase and must notify the Company within the warranty period.

For warranty service: Call toll free 800-445-1805, or write to *Pramac America, LLC, Product Services, 4970 Airport Road, P. O. Box 6001, Kearney, NE 68847.*

EXCLUSIONS AND LIMITATIONS: THE COMPANY MAKES NO OTHER WARRANTY OF ANY KIND, EXPRESS OR IMPLIED. IMPLIED WARRANTIES, INCLUDING WARRANTIES OF MERCHANTABILITY AND OF FITNESS FOR A PARTICULAR PURPOSE, ARE HEREBY DISCLAIMED. THE WARRANTY SERVICE DESCRIBED ABOVE IS THE EXCLUSIVE REMEDY UNDER THIS WARRANTY; LIABILITY FOR INCIDENTAL AND CONSEQUENTIAL DAMAGES IS EXCLUDED TO THE EXTENT PERMITTED BY LAW.

This warranty gives you specific legal rights, and you may also have other rights which vary from state to state. Some states do not allow a disclaimer of implied warranties, or the exclusion or limitation of incidental and consequential damages, so the above disclaimers and exclusions may not apply to you.

REGISTER YOUR PRODUCT

Register your Powermate® generator online at www.powermate.com.

