



FOR MODELS:

WGen2000
Portable Generator
2000 Running Watts
2500 Peak Watts

WGen3600
Portable Generator
3600 Running Watts
4650 Peak Watts

WGen3600v
Portable Generator
3600 Running Watts
4650 Peak Watts

California

Proposition 65 Warning

The engine exhaust from this product contains chemicals known to the state of California to cause cancer, birth defects or other reproductive harm.

California

Proposition 65 Warning

Certain components in this product and its related accessories contain chemicals known to the state of California to cause cancer, birth defects or other reproductive harm. Wash hands after handling.

DISCLAIMERS:

All information, illustrations and specifications in this manual are based on the latest information available at the time of publishing. The illustrations used in this manual are intended as representative reference views only. Moreover, because of our continuous product improvement policy, we may modify information, illustrations and/or specifications to explain and/or exemplify a product, service or maintenance improvement. We reserve the right to make any change at any time without notice. Some images may vary depending upon which model is shown.

ALL RIGHTS RESERVED:

No part of this publication may be reproduced or used in any form by any means – graphic, electronic or mechanical, including photocopying, recording, taping or information storage and retrieval systems – without the written permission of MWE Investments LLC.

DANGER



This manual contains important instructions for operating this generator. For your safety and the safety of others, be sure to read this manual thoroughly before operating the generator. Failure to properly follow all instructions and precautions can cause you and others to be seriously hurt or killed.

WGen TECHNICAL SPECIFICATIONS

Model Number	Running Watts	Peak Watts	Fuel Tank Size (L/G)	Rated Speed (RPM)	Ignition Type	Spark plug	Engine Disp (cc)	Stroke X Bore	Oil Capacity (L)	Oil Type	THD
WGen2000	2000	2500	15/4.0	3600	TCI	F7TC	212	55X70	0.60	10W30	<23%
WGen3600	3600	4650	15/4.0	3600	TCI	F7TC	212	55X70	0.60	10W30	<23%
WGen3600v	3600	4650	15/4.0	3600	TCI	F7TC	212	55X70	0.60	10W30	<23%

NOTICE

Even with a carburetor modification, engine horsepower will decrease about 3.5% for each 300 meter (1,000 foot) increase in altitude. The effect of altitude on horsepower will be greater if no carburetor modification is made. A decrease in engine horsepower will decrease the power output of the generator.

HAVE QUESTIONS?

Email us at service@wpowereq.com

or call 1-855-944-3571

FOR YOUR RECORDS:

Date of Purchase:	
Generator Model Number:	
Purchased from Store/Dealer:	
Generator Serial Number:	

IMPORTANT: KEEP YOUR PURCHASE RECEIPT TO ENSURE TROUBLE-FREE WARRANTY COVERAGE.



PRODUCT REGISTRATION

To ensure trouble-free warranty coverage, it is important you register your Westinghouse generator. You can register your generator by either:

1. Filling in the product registration form below and mailing to:

Product Registration
 MWE Investments LLC
 777 Manor Park Drive
 Columbus, Ohio 43228

2. Registering your product Online at www.westinghouseportablepower.com/register-your-product/
 To register your generator you will need to locate the following information:

 Westinghouse MWE Investments LLC Columbus Ohio 43228 USA MWE Investments LLC Columbus Ohio 43228 Etats-Unis	Model Modèle Part No. Numéro de pièce	Power (Rated) Puissance (Nom.)	Insul Class Classe Isol.	Serial No./No. De Série	 CSA Master Contract Number : 268850 Numéro de contrat principal de CSA 268850
	AC Voltage Tension CA	Power (Peak) Puissance (Pointe)	Max Amb Temp Temp. Amb. Max	Duty Service	
AC Current Intensité CA	Frequency Fréquence	RPM TR/MIN	Designed in Columbus, Ohio USA Conçu à Columbus, Ohio, États-Unis	Made in China/ Fabriqué en Chine	

WESTINGHOUSE PRODUCT REGISTRATION FORM

PERSONAL INFORMATION

GENERATOR INFORMATION

First Name: _____ Model Number: _____

Last Name: _____ Serial Number: _____

Street Address: _____ Date Purchased: _____

Street Address: _____ Purchased From: _____

City, State, ZIP: _____

Country: _____

Phone Number: _____

E-Mail: _____



TABLE OF CONTENTS

WGEN TECHNICAL SPECIFICATIONS	2	Checking Engine Oil	20
PRODUCT REGISTRATION	3	Adding Engine Oil	20
For Your Records:	3	Changing Engine Oil	21
Product Registration	3	Air Filter Maintenance	21
Product Registration Form	3	Cleaning the Air Filter	21
SAFETY	5	Spark Plug Maintenance	22
Safety Definitions	5	Cleaning the Generator	23
Safety Symbol Definitions	5	Storage	23
General Safety Rules	6	Checking and Adjusting Valve Lash.	23
Safety Labels and Decals	7	TROUBLE SHOOTING	24
UNPACKING	9	EXPLODED AND ENGINE VIEWS	26
What Comes in the Box	9	WGen2000 Engine View	26
Wheel Kit Accessories Box (WGen3600)	9	WGen2000 Exploded View	27
ASSEMBLY -WGen3600	10	WGen3600 Engine View	28
Installing Wheels and Feet	10	WGen3600 Exploded View	29
FEATURES	11	WGen3600v Engine View	30
Generator Features	11	WGen3600v Exploded View	31
Control Panel Features	13	SCHEMATICS	32
OPERATION	14	WGen3600/WGen3600v Schematic	32
Before Starting the Generator	14	WGen2000 Schematic	33
Engine Fluids and Fuel	15		
Adding Gasoline to the Fuel Tank	16		
Starting the Generator	17		
Manually Starting the Generator	17		
Stopping the Generator	18		
Normal Operation	18		
During an Emergency	18		
MAINTENANCE	19		
Maintenance Schedule	19		
Engine Oil Maintenance	20		
Engine Oil Specification	20		

SAFETY

SAFETY DEFINITIONS

The words DANGER, WARNING, CAUTION and NOTICE are used throughout this manual to highlight important information. Be certain that the meanings of these alerts are known to all who work on or near the equipment.



This safety alert symbol appears with most safety statements. It means attention, become alert, your safety is involved! Please read and abide by the message that follows the safety alerts symbol.

DANGER

Indicates a hazardous situation which, if not avoided, *will* result in death or serious injury.

WARNING

Indicates a hazardous situation which, if not avoided, *could* result in death or serious injury.

CAUTION

Indicates a hazardous situation which, if not avoided, *could* result in minor or moderate injury.

NOTICE

Indicates a situation which can cause damage to the generator, personal property and/or the environment, or cause the equipment to operate improperly.

NOTE: Indicates a procedure, practice or condition that should be followed in order for the generator to function in the manner intended.

SAFETY SYMBOL DEFINITIONS

Symbol	Description
	Safety Alert Symbol
	Asphyxiation Hazard
	Burn Hazard
	Burst/Pressure Hazard
	Don't leave tools in the area
	Electrical Shock Hazard
	Explosion Hazard
	Fire Hazard
	Lifting Hazard
	Pinch-Point Hazard
	Read Manufacturer's Instructions
	Read Safety Messages Before Proceeding
	Wear Personal Protective Equipment (PPE)

SAFETY

GENERAL SAFETY RULES

DANGER



Never use the generator in a location that is wet or damp. Never expose the generator to rain, snow, water spray or standing water while in use. Protect the generator from all hazardous weather conditions. Moisture or ice can cause a short circuit or other malfunction in the electrical circuit.



Never operate the generator in an enclosed area. Engine exhaust contains carbon monoxide. Only operate the generator outside and away from windows, doors and vents.

WARNING



Voltage produced by the generator could result in death or serious injury.

- Never operate the generator in rain or a flood plain unless proper precautions are taken to avoid being subject to rain or a flood.
- Never use worn or damaged extension cords.
- Always have a licensed electrician connect the generator to the utility circuit.
- Never touch an operating generator if the generator is wet or if you have wet hands.
- Never operate the generator in highly conductive areas such as around metal decking or steel works.
- Always use grounded extension cords. Always use three-wire or double-insulated power tools.
- Never touch live terminals or bare wires while the generator is operating.
- Be sure the generator is properly grounded before operating.

WARNING



Gasoline and gasoline vapors are extremely flammable and explosive under certain conditions.

- Always refuel the generator outdoors, in a well-ventilated area.
- Never remove the fuel cap with the engine running.
- Never refuel the generator while the engine is running. Always turn engine off and allow the generator to cool before refueling.
- Only fill fuel tank with gasoline.
- Keep sparks, open flames or other form of ignition (such as match, cigarette, static electric source) away when refueling.
- Never overfill the fuel tank. Leave room for fuel to expand. Overfilling the fuel tank can result in a sudden overflow of gasoline and result in spilled gasoline coming in contact with HOT surfaces. Spilled fuel can ignite. If fuel is spilled on the generator, wipe up any spills immediately. Dispose of rag properly. Allow area of spilled fuel to dry before operating the generator.
- Wear eye protection while refueling.
- Never use gasoline as a cleaning agent.
- Store any containers containing gasoline in a well-ventilated area, away from any combustibles or source of ignition.
- Check for fuel leaks after refueling. Never operate the engine if a fuel leak is discovered.

WARNING



Never operate the generator if powered items overheat, electrical output drops, there is sparking, flames or smoke coming from the generator, or if the receptacles are damaged.



Never use the generator to power medical support equipment.



Always remove any tools or other service equipment used during maintenance from the generator before operating.

NOTICE

Never modify the generator.

Never operate the generator if it vibrates at high levels, if engine speed changes greatly or if the engine misfires often.

Always disconnect tools or appliances from the generator before starting.

SAFETY

SAFETY LABELS AND DECALS

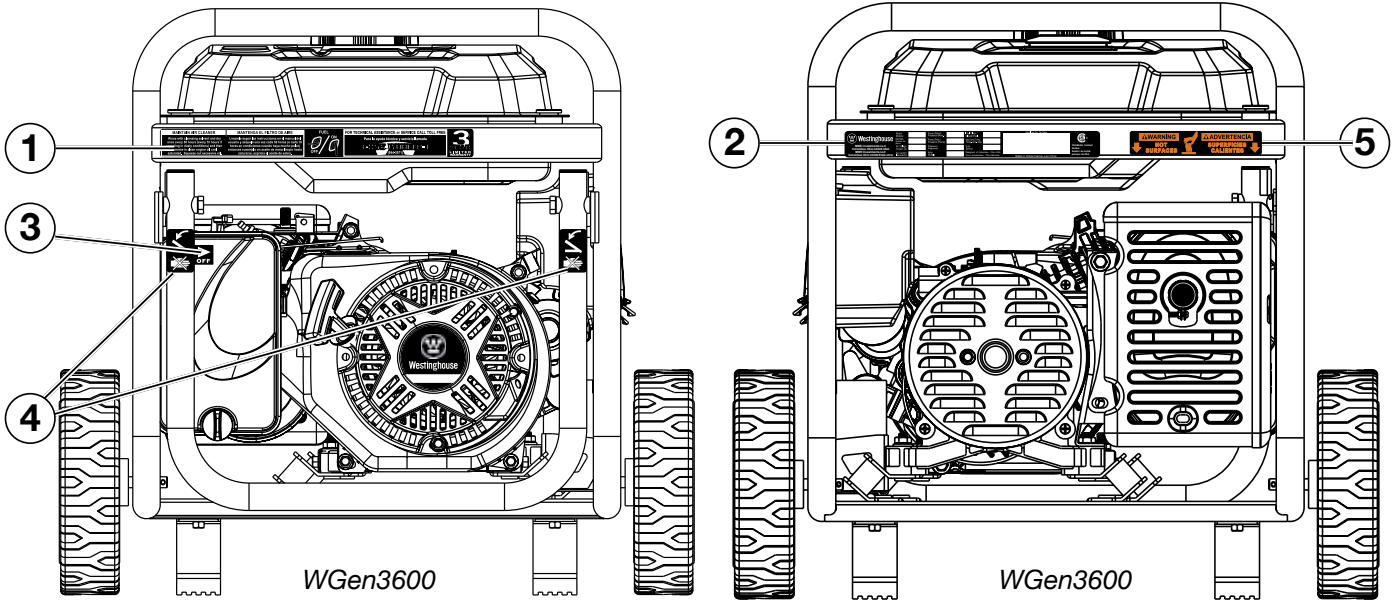

1

MAINTAIN AIR CLEANER Rinse with cleansing solvent and dry once every 50 hours (every 10 hours if operating in dusty conditions) and then immerse in clean engine oil until saturated. Squeeze out excessive oil.	MANTENGA EL FILTRO DE AIRE Limpielo según las instrucciones en el manual del usuario y séquelo una vez cada 50 horas (o cada 10 horas en condiciones cuando haya mucho polvo) entonces sumérjalo en aceite de motor limpio hasta saturarse, exprima el aceite de sobra.	FUEL 	FOR TECHNICAL ASSISTANCE or SERVICE CALL TOLL FREE Para la ayuda técnica y servicio llamada 1-855-944-3571 3 YEAR LIMITED WARRANTY
--	---	-----------------	--

2

Westinghouse MWE Investments LLC Columbus Ohio 43228 USA MWE Investments LLC Columbus Ohio 43228 Etats-Unis	Model Modèles	Power (Rated) Puissance (Nom.)	Insul Class Classe Isol.	Serial No./No. De Série	 CSA Master Contract Number : Numéro de contrat principal de CSA
	Part No. Numéro de pièce	Power (Peak) Puissance (Pointe)	Max Amb Temp Temp. Amb. Max	Duty Service	

3

4

5

SAFETY

SAFETY LABELS AND DECALS

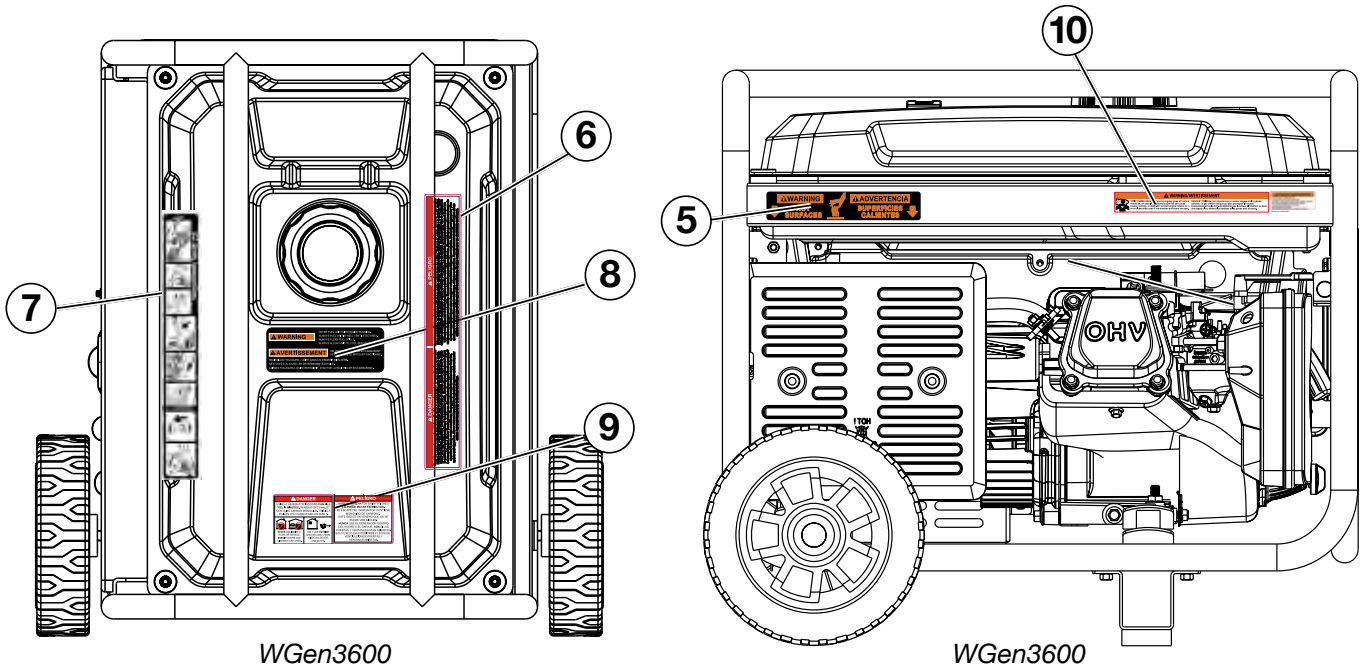

6 **⚠ DANGER** Read the owner's manual and follow all safety procedures prior to operating the generator. Failure to follow these instructions may lead to serious injury, property damage or death. Never add fuel to generator when the engine is hot or running. Never allow fuel to come in contact with running engine or hot generator parts. Always allow engine to cool down before adding fuel. Never touch hot surfaces. Generators pose risk of shock especially if operated in damp or wet conditions. Keep generator and stored fuel away from fire, sparks and cigarettes. Never connect to a building's electrical system unless a transfer switch has been installed by a certified electrician.

⚠ PELIGRO Lea el manual del propietario y siga todos los procedimientos de seguridad antes de hacer funcionar el generador. El incumplimiento de estas instrucciones puede causar lesiones graves, daños a la propiedad o la muerte. Nunca agregue combustible al generador cuando el motor está caliente o en marcha. Nunca permita que el combustible entre en contacto con el motor en marcha o partes calientes del generador. Siempre permita que el motor se enfríe antes de agregar combustible. Nunca toque las superficies calientes. Generadores presentan un riesgo de choque especialmente en caso de operar en condiciones húmedas o mojadas. Mantenga el generador y se almacena el combustible alejado del fuego, chispas o cigarrillos. Nunca conecte al sistema eléctrico de un edificio a menos que un interruptor de transferencia ha sido instalado por un electricista certificado.



8 **⚠ WARNING** NEVER FUEL UNIT WITH ENGINE RUNNING. ALWAYS FUEL UNIT IN WELL VENTILATED AREA. ALWAYS CLEAN FUEL SPILLS. ALWAYS ALLOW UNIT TO COOL BEFORE FUELING.

⚠ AVERTISSEMENT NE JAMAIS RAVITAILLER EN CARBURANT PENDANT QUE LE MOTEUR FONCTIONNE. NETTOYEZ TOUJOURS LES DÉVERSEMENTS D'HUILE. LÂSSEZ TOUJOURS L'UNITÉ REFRIGÉRIR AVANT DE LA RAVITAILLER EN CARBURANT.

9 **⚠ DANGER** USING A GENERATOR INDOORS CAN KILL YOU IN MINUTES. GENERATOR EXHAUST CONTAINS CARBON MONOXIDE. THIS IS A POISON YOU CANNOT SEE OR SMELL.

⚠ PELIGRO USAR EL GENERADOR EN INTERIORES LO PUEDE MATAR EN MINUTOS. EL ESCAPE DEL GENERADOR CONTIENE MONÓXIDO DE CARBONO. ESTE GAS ES UN VENENO QUE NO SE PUEDE VER NI OLER. NUNCA USE EL GENERADOR DENTRO DEL HOGAR O EL GARAJE, AÚN SI LAS PUERTAS Y VENTANAS ESTÁN ABIERTAS. SOLO ÚSELO EN EXTERIORES Y LEJOS DE VENTILACIONES, PUERTAS Y VENTANAS ABIERTAS.

NEVER USE INSIDE A HOME OR GARAGE. EVEN IF DOORS AND WINDOWS ARE OPEN. ONLY USE OUTSIDE AND FAR AWAY FROM WINDOWS, DOORS, AND VENTS.

10 **⚠ WARNING/AVERTISSEMENT**

TOXIC FUMES HAZARD. Running engines gives off carbon monoxide, an odorless poisonous gas that can cause nausea, fainting, or death. Do not start engine indoors or in an enclosed area, even if the windows and doors are open.



DANGER TOXIQUE. Faire fonctionner un moteur dégage de l'oxyde de carbone, un gaz inodore toxique qui peut provoquer la nausée, évanouissement ou la mort. Ne démarrer pas le moteur à l'intérieur ou dans une espace clos, même si les fenêtres et les portes sont ouvertes.

⚠ WARNING/AVERTISSEMENT

FOR ELECTRICAL EQUIPMENT ONLY
POUR MATÉRIEL ÉLECTRIQUE SEULEMENT
FOR USE IN A WEATHER PROTECTED WELL VENTILATED AREA
EMPLOYEZ UNIQUEMENT DANS UN EMPLACEMENT À L'ABRI DES INTÉMPÉRIES ET BIEN AÉRÉ
NEUTRAL WIRE TO FRAME
NEUTRE WIRE À LA CARCASSE DU MOTEUR

Sample from WGen5500

UNPACKING

⚠ CAUTION	
	Always have assistance when lifting the generator. The generator is heavy; lifting it could cause bodily harm.
	Avoid cutting on or near staples to prevent personal injury.

Tools required – box cutter or similar device.

1. Carefully cut the packing tape on top of the carton.
2. Fold back top flaps to reveal the manual.
3. Remove the Wheel Kit Accessories (WGen3600 only) cardboard box.
4. Carefully cut two sides of the carton to remove the generator.

WHAT COMES IN THE BOX

- Manual
- Quick Start Guide/Maintenance Schedule
- 0.6 Liter Bottle of SAE 10W30 Oil (1)
- Spark Plug Socket Wrench (1)
- Wheel Kit Accessories Box (WGen3600 Only)
- Funnel (1)

WHEEL KIT ACCESSORIES BOX (WGEN3600 ONLY)

Open the Wheel Kit Accessories box and verify the contents against the list right. If any parts are missing, please locate an authorized Westinghouse Generator dealer at service@wpowerreq.com or call 1-855-944-3571.

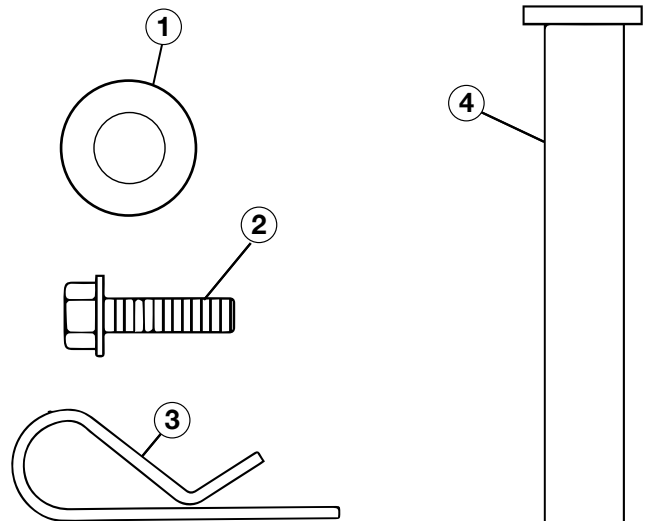

Figure 1 - (WGen3600 only) Wheel and Feet Kit Hardware

1. Washer (2 used)
2. Flange Bolt M8 x16mm (4 used)
3. Hairpin Cotter Pin (2 used)
4. Wheel Axle Pin (2)



ASSEMBLY - WGen3600

INSTALLING WHEELS AND FEET



BEFORE ASSEMBLING THE GENERATOR, REVIEW THE SAFETY SECTION STARTING ON PAGE 5.

⚠ CAUTION



Never lift the generator without assistance. The generator is heavy and lifting without assistance could result in personal injury.



Never use the handles as a lifting point to support the entire weight of the generator. Only use the handles to move the generator by lifting the handles and using the wheels to move the generator.



Use caution when collapsing the handles. Hands and fingers could get caught and pinched.

NOTICE

Assembling the generator will require lifting the unit on one side. Make sure all engine oil and fuel are drained from the unit prior to assembling. Once assembled, the wheel kit is not intended for on-road use. The wheel kit is designed for use on this generator only.

INSTALLING FEET TO FRAME (WGen3600 Only)

1. Place generator on a flat surface.
2. Place a piece of cardboard or other soft material to tip the generator onto, to protect the frame paint and prevent the generator from sliding. Tip the generator onto the side.
3. Install the mounting foot to the frame using M8 flange bolts.

- 1 - Mounting Feet
- 2 - Flange Bolts M8

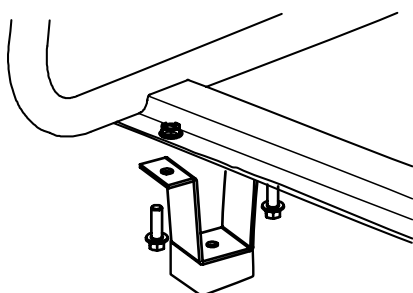

Figure 1 - Assemble Mounting Feet to Frame

INSTALLING WHEELS TO FRAME (WGen3600 Only)

1. Insert axle pin through washer and wheel.

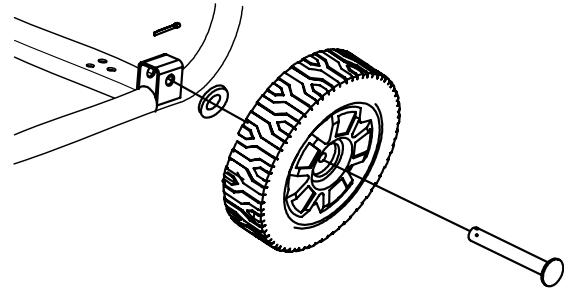

Figure 2 - Wheel Assembly

2. Install the wheel with axle pin through the axle bracket on the frame. The eye of the bolt should be facing toward the inside of the generator.

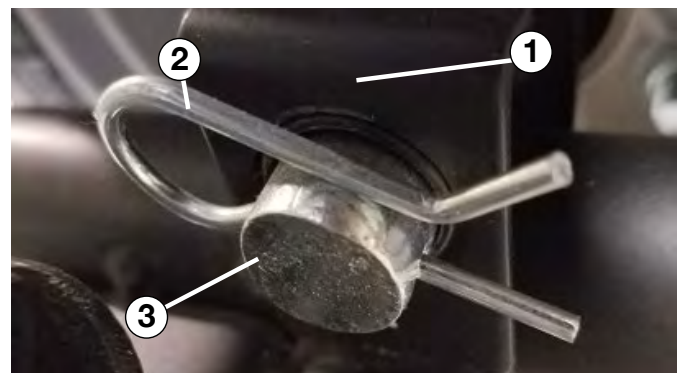

Figure 3 - Assemble Wheel to Frame

3. Install the hairpin cotter through the axle pin to lock it in place.
- 1 - Axle Bracket
 - 2 - Hairpin Clip
 - 3 - Axle Pin
4. Repeat previous steps on other wheel.

FEATURES



- ① **Engine Control Switch:** Allows fuel to flow to engine and energizes the ignition system.
- ② **Fuel Cap:** Close until clicking sound is heard.
- ③ **Control Panel:** Contains the circuit breakers and outlets.
- ④ **Oil Fill Plug/Dipstick:** Must be removed to add and check oil.
- ⑤ **Oil Drain Plug:** Must be removed to drain engine oil
- ⑥ **Never Flat Wheels (WGen3600 Only):** For easy portability
- ⑦ **Fuel Shut off Valve:** Controls the flow of fuel to the engine.
- ⑧ **Manual Choke:** Choke must be set manually by adjusting choke lever.
- ⑨ **Single Piece Handle (WGen3600 Only):** Includes rubber grip. Allows you to easily push or pull unit with one hand.



FEATURES



- ① **Fuel Gauge:** Indicates fuel level.
- ② **Spark Plug Boot (Wire):** Must be removed when servicing the engine or the spark plug.
- ③ **CARB Canister:** Required for models sold into and used in California.
- ④ **Muffler and Spark Arrester:** Avoid contact until engine is cooled down. Spark arrester prevents sparks from exiting the muffler. It must be removed for servicing.



WGen2000 | WGen3600v

FEATURES

CONTROL PANEL FEATURES

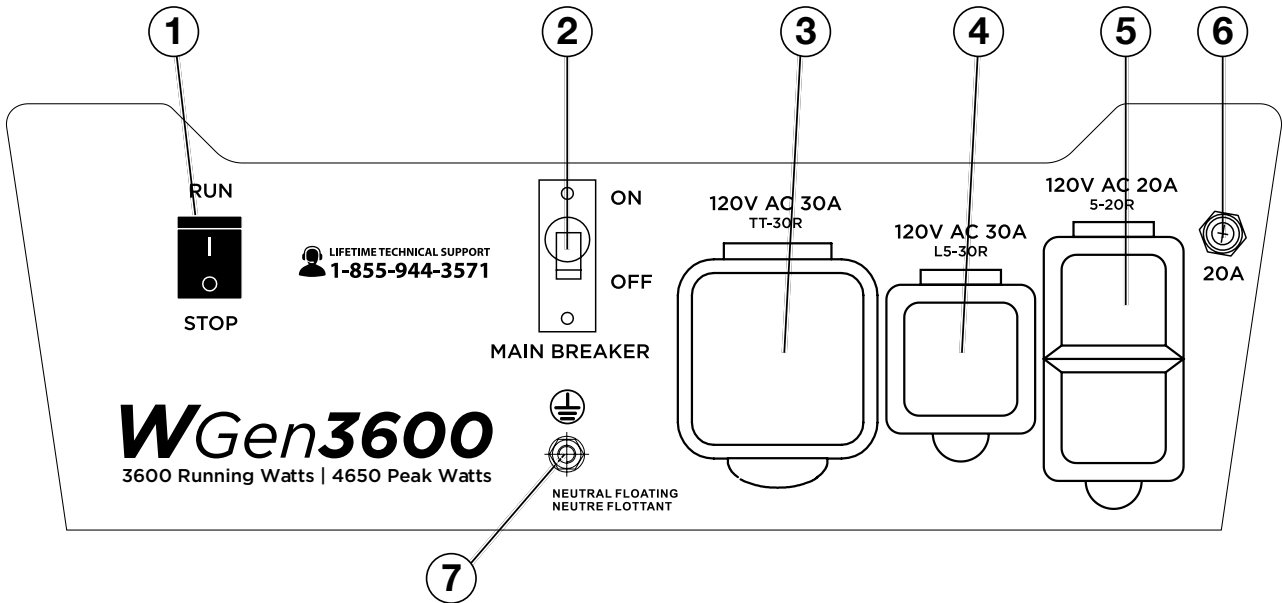

- ① **Engine Control Switch:** Allows fuel to flow to engine and energizes the ignition system.
- ② **Main Circuit Breaker:** The main circuit breaker controls total output of all outlets to protect the generator.
- ③ **120-Volt 30 Amp TT-30R Outlet:** Travel Trailer outlet can supply a maximum of 30 amps and 120 volts.
- ④ **120-Volt, 30 Amp Twistlock Outlet (L5-30R):** Outlet can supply 120V output.
- ⑤ **120-Volt, Duplex Outlets (NEMA 5-20R):** Each outlet is capable of carrying a maximum of 20 (18 amps WGen2000) amps on a single receptacle or a combination of both receptacles.
- ⑥ **20-Amp Circuit Breakers:** This circuit breaker limits the current that can be delivered through the 120-volt duplex outlets to 20amps.
- ⑦ **Ground Terminal:** The ground terminal is used to ground the generator.

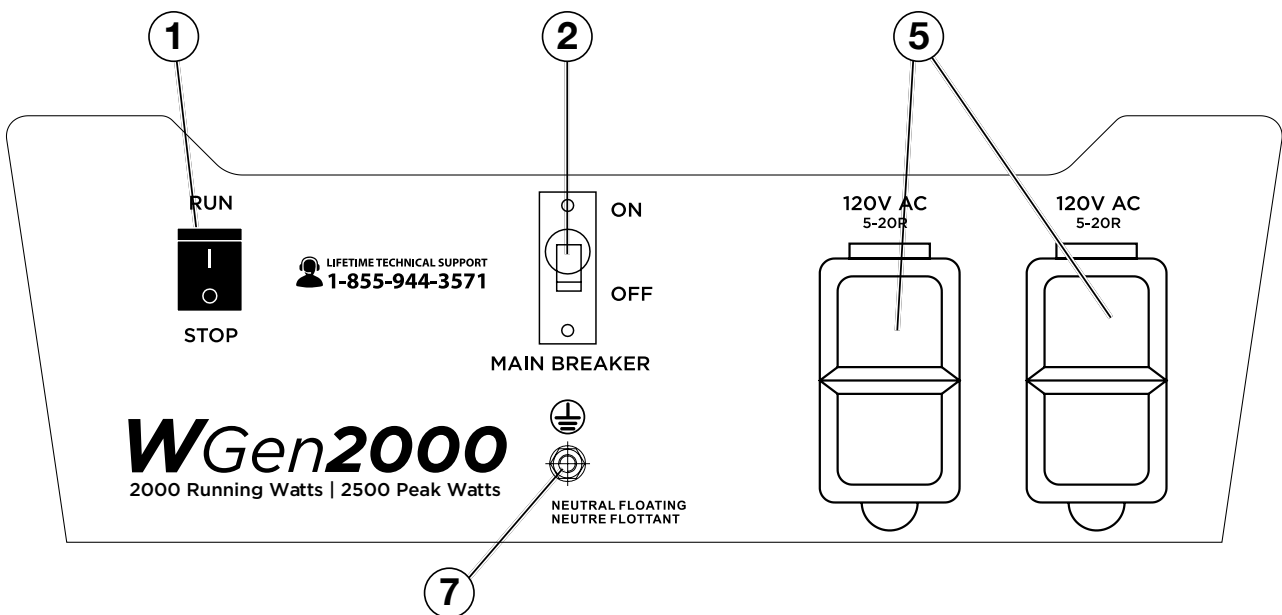

OPERATION

BEFORE STARTING THE GENERATOR



BEFORE STARTING THE GENERATOR, REVIEW SAFETY SECTION STARTING ON PAGE 5.

Location Selection – Before starting the generator, avoid exhaust and location hazards by verifying:

- You have selected a location to operate the generator that is outdoors and well ventilated.
- You have selected a location with a level and solid surface on which to place the generator.
- You have selected a location that is at least 6 feet (1.8 m) away from any building, other equipment or combustible material.
- If the generator is located close to a building, make sure it is not located near any windows, doors and/or vents.

⚠ DANGER

Using a generator indoors **CAN KILL YOU IN MINUTES.** Generator exhaust contains carbon monoxide. This is a poison you cannot see or smell.



NEVER use inside a home or garage, **EVEN IF** doors and windows are open.



Only use **OUTSIDE** and far away from windows, doors, and vents.

Avoid other generator hazards. **READ MANUAL BEFORE USE.**

⚠ WARNING



Always operate the generator on a level surface. Placing the generator on non level surfaces can cause the generator to tip over, causing fuel and oil to spill. Spilled fuel can ignite if it comes in contact with an ignition source such as a very hot surface.

NOTICE

Only operate the generator on a solid, level surface. Operating the generator on a surface with loose material such as sand or grass clippings can cause debris to be ingested by the generator that could:

- Block cooling vents
- Block air intake system

Weather – Never operate your generator outdoors during rain, snow or any combination of weather conditions that could lead to moisture collecting on, in or around the generator.

Dry Surface – Always operate the generator on a dry surface free of any moisture.

No Connected Loads – Make sure the generator has no connected loads before starting it. To ensure there are no connected loads, unplug any electrical extension cords that are plugged into the control panel receptacles.

NOTICE

Starting the generator with loads already applied to it could result in damage to any appliance being powered off the generator during the brief start-up period.

Grounding the Generator – The National Electric Code (NEC), as well as many local electrical codes, may require the generator to be connected to earth ground. The most common application that requires a ground rod is when you are using the generator as a separately derived system to provide back up power to your house. Typically this is when a transfer switch has a switched neutral.

As the generator application has many variables that cannot be determined by the manufacturer of the generator, a licensed electrician will need to determine if a grounding rod is needed.

If a licensed electrician has determine the application requires a ground rod, make sure it is connected to earth ground by connecting the ground terminal on the control panel to earth ground using copper wire (minimum 10 AWG). Consult a qualified electrician for local grounding requirements.

Floating Neutral (WGen2000, WGen3600 & WGen3600v): The generator (stator winding) is isolated from the frame and from the AC receptacle ground pin.

⚠ WARNING



Be sure the generator is properly connected to earth ground before operating. The generator must be grounded to prevent electrical shock due to faulty appliances.

OPERATION

ADDING / CHECKING ENGINE FLUIDS AND FUEL



BEFORE ADDING/CHECKING ENGINE FLUIDS AND FUEL, REVIEW SAFETY SECTION STARTING ON PAGE 5.

DANGER



Filling the fuel tank with gasoline while the generator is running can cause gasoline to leak and come in contact with hot surfaces that can ignite the gasoline.

Before starting the generator, always check the level of:

- Engine oil
- Gasoline in the fuel tank

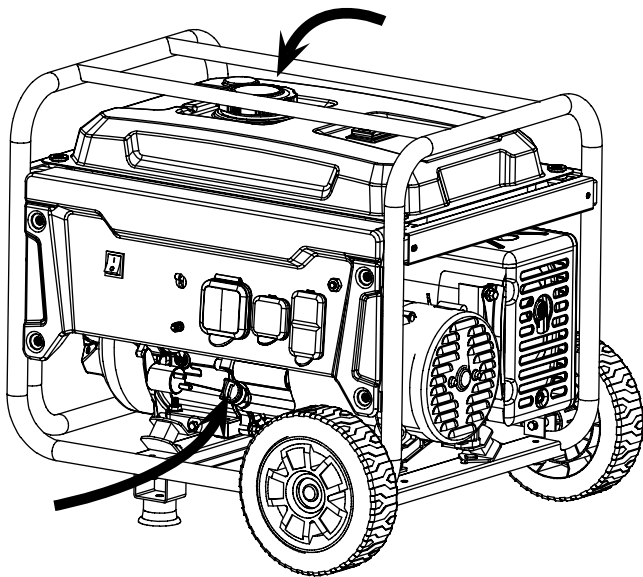

Figure 5

Once the generator is started and the engine gets warm, it is not safe to add gasoline to the fuel tank or engine oil to the engine while the engine is running or the engine and muffler are hot.

CHECKING AND / OR ADDING ENGINE OIL

WARNING



Internal pressure can build in the engine crankcase while the engine is running. Removing the oil fill plug/dipstick while the engine is hot can cause extremely hot oil to spray out of the crankcase and can severely burn skin. Allow engine oil to cool for several minutes before removing the oil fill plug/dipstick.

The unit as shipped does not contain oil in the engine. You must add engine oil before starting the generator for the first time. See *Checking Engine Oil* and *Adding Engine Oil* on page 20 for instructions on checking engine oil level and the procedure for adding engine oil.

NOTICE

The engine does not contain engine oil as shipped. Attempting to start the engine can damage engine components. The owner of the generator is responsible to ensure the proper oil level is maintained during the operation of the generator. Failure to maintain the proper oil level can result in engine damage.

OPERATION

ADDING GASOLINE TO THE FUEL TANK

⚠ WARNING



Never refuel the generator while the engine is running.



Always turn the engine off and allow the generator to cool before refueling.

Required Gasoline – Only use gasoline that meets the following requirements:

- Unleaded gasoline only
- Gasoline with maximum 10% ethanol added
- Gasoline with an 87 octane rating or higher

Filling the Fuel Tank – Follow the steps below to fill the fuel tank:

1. Shut off the generator.
2. Allow the generator to cool down so all surface areas of the muffler and engine are cool to the touch.
3. Move the generator to a flat surface.
4. Clean area around the fuel cap.
5. Remove the fuel cap by rotating counterclockwise.
6. Slowly add gasoline into the fuel tank. Be very careful not to overfill the tank. The gasoline level should NOT be higher than the filler neck (see Figure 6).
7. Install the fuel cap by rotating clockwise until you hear a click, indicating the cap is completely installed.

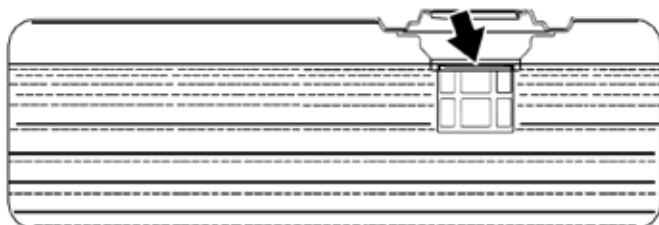

Figure 6 - Maximum Gasoline Fill Level

⚠ CAUTION



Avoid prolonged skin contact with gasoline. Avoid prolonged breathing of gasoline vapors.

BEFORE STARTING THE GENERATOR



BEFORE STARTING THE GENERATOR, REVIEW SAFETY SECTION STARTING ON PAGE 5.

Before attempting to start the generator, verify the following:

- The engine is filled with engine oil. See *Checking Engine Oil* on page 20.
- The generator is situated in a proper location (*Location Selection* on page 14).
- The generator is on a dry surface (*Weather and Dry Surface* on page 14).
- All loads are disconnected from the generator (*No Connected Loads* on page 14).
- The generator is properly grounded the Generator (page 14).

⚠ DANGER



Never use the generator in a location that is wet or damp. Never expose the generator to rain, snow, water spray or standing water while in use. Protect the generator from all hazardous weather conditions. Moisture or ice can cause a short circuit or other malfunction in the electrical circuit.



Never operate the generator in an enclosed area. Engine exhaust contains carbon monoxide. Only operate the generator outside and away from windows, doors and vents.

NOTICE

The engine is equipped with a low oil shutdown switch. If the oil level becomes low, the engine may shut down and not start until the oil is filled to the proper level. Poor oil quality may interfere with the operation of the low oil shutdown switch.

The owner of the generator is responsible to ensure the proper oil level is maintained during the operation of the generator. Failure to maintain the proper oil level can result in engine damage.

OPERATION

MANUALLY STARTING THE GENERATOR

1. Check oil levels (see *Adding Engine Oil* page 20)
2. Make sure the circuit breakers are properly set (see Figure 7 below).

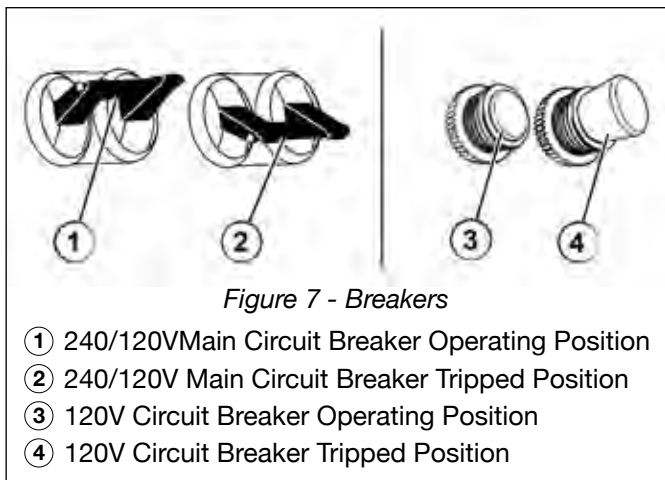

3. Move the fuel shut off valve to the ON position (see Figure 8 below).

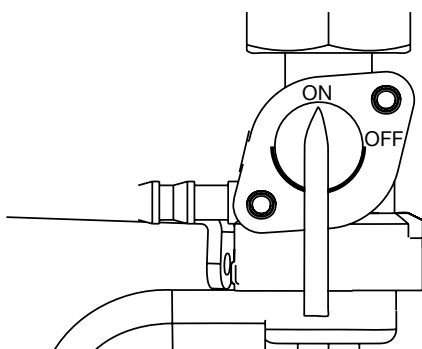

Figure 8 - Fuel Shut Off - ON

4. Move the choke lever to the "ON" position (see Figure 9 below).

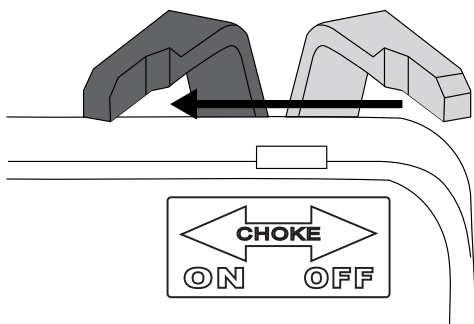

Figure 9 - Choke Lever - ON

5. Push the engine control switch into the RUN position (see Figure 10 below).

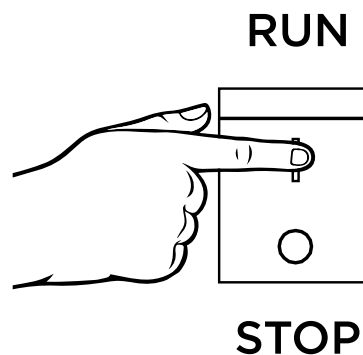

Figure 10 - Engine Control Switch - RUN

6. Firmly grasp and pull the recoil handle slowly until you feel increased resistance. At this point, apply a rapid pull while pulling up and slightly away from the generator (see Figure 11).

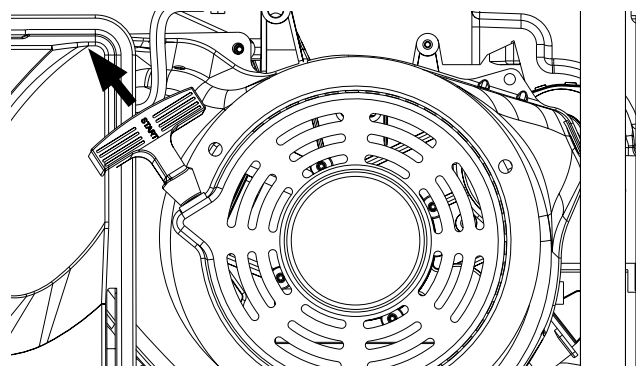

Figure 11 - Engine Recoil Handle - PULL

7. As the engine starts and stabilizes, gradually move the choke lever back to the OFF position (see Figure 12 below).

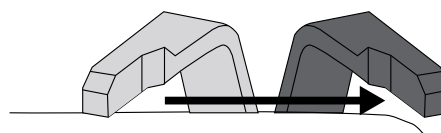

Figure 12 - Choke Lever - OFF

OPERATION

STOPPING THE GENERATOR

Normal Operation

During normal operation, use the following steps to stop your generator:

1. Remove any connected loads from the control panel receptacles.
2. Allow the generator to run at “no load” to reduce and stabilize engine and alternator temperatures.
3. Position the engine control switch to **STOP** or if you plan to store the generator after use, turn the fuel shutoff valve to the **OFF** position and allow the fuel to be consumed from the carburetor. (see figure 13)

During an Emergency

If there is an emergency and the generator must be stopped quickly, position the engine control switch to the **STOP** position immediately.

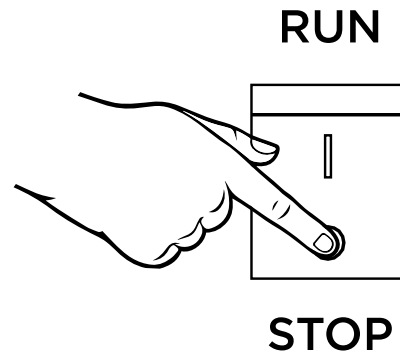

Figure 13 - Move engine switch to STOP

MAINTENANCE



BEFORE PERFORMING MAINTENANCE ON THE GENERATOR, REVIEW THE SAFETY SECTION STARTING ON PAGE 5, AS WELL AS THE FOLLOWING SAFETY MESSAGES.

⚠ WARNING



Avoid accidentally starting the generator during maintenance by removing the spark plug boot from the spark plug. For electric start generators, also disconnect the battery cables from the battery (disconnect the black negative (-) cable first) and place the cables away from the battery posts to avoid arcing.



Allow hot components to cool to the touch prior to performing any maintenance procedure.

⚠ WARNING



Internal pressure can build in the engine crankcase while the engine is running. Removing the oil fill plug/dipstick while the engine is hot can cause extremely hot oil to spray out of the crankcase and can severely burn skin. Allow engine oil to cool for several minutes before removing the oil fill plug/dipstick.



Always perform maintenance in a well-ventilated area. Gasoline fuel and fuel vapors are extremely flammable and can ignite under certain conditions.

MAINTENANCE

MAINTENANCE SCHEDULE

⚠ WARNING



Failure to perform periodic maintenance or not following maintenance procedures can cause the generator to malfunction and could result in death or serious injury.

NOTICE

Periodic maintenance intervals vary depending on generator operating conditions. Operating the generator under severe conditions, such as sustained high-load, high-temperature, or unusually wet or dusty environments, will require more frequent periodic maintenance. The intervals listed in the maintenance schedule should be treated only as a general guideline.

⚠ CAUTION



Avoid skin contact with engine oil or gasoline. Prolonged skin contact with engine oil or gasoline can be harmful. Frequent and prolonged contact with engine oil may cause skin cancer. Take protective measures and wear protective clothing and equipment. Wash all exposed skin with soap and water.

Following the maintenance schedule is important to keep the generator in good operating condition. The following is a summary of maintenance items by periodic maintenance intervals.

TABLE 1: MAINTENANCE SCHEDULE - OWNER PERFORMED

Maintenance Item	Before Every Use	After First 20 Hours or First Month of Use	After 50 Hours of Use or Every 6 Months	After 100 Hour of Use or Every 6 Months	After 300 Hours of Use or Every Year
Engine Oil	Check Level	Change	Change	-	-
Cooling Features	Check/Clean	-	-	-	-
Air Filter	Check	-	Clean*	-	Replace
Spark Plug	-	-	-	Check/Clean	Replace
Spark Arrestor	-	-	-	Check/Clean	-

*Service more frequently if operating in dry and dusty conditions

TABLE 2: MAINTENANCE SCHEDULE - AUTHORIZED WESTINGHOUSE SERVICE DEALER PERFORMED

Maintenance Item	Before Every Use	After First 20 Hours or First Month of Use	After 50 Hours of Use or Every 6 Months	After 100 Hour of Use or Every 6 Months	After 300 Hours of Use or Every Year
Valve Clearance	-	-	-	-	Check/Adjust
Fuel Filter	-	-	-	Check/Clean	-
Idle Speed	-	-	-	-	Check/Adjust

MAINTENANCE

ENGINE OIL MAINTENANCE

Engine Oil Specification

1. Only use the engine oil specified in Figure 14.
2. Only use 4-stroke/cycle engine oil. **NEVER USE 2-STROKE/CYCLE OIL.** Synthetic oil is an acceptable substitute for conventional oil.

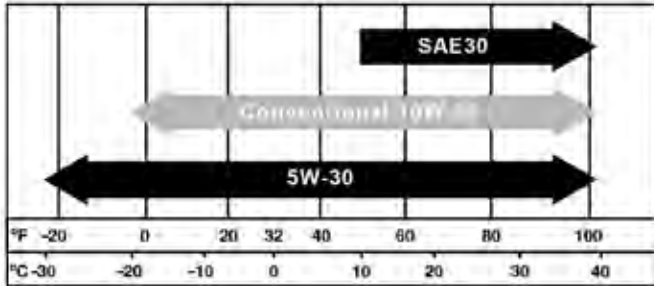

Figure 14 - Recommended Oil

CHECKING ENGINE OIL

NOTICE

Always maintain proper engine oil level. Failure to maintain proper engine oil level could result in severe damage to the engine and/or shorten the life of the engine. Always use the specified engine oil. Failure to use the specified engine oil can cause accelerated wear and/or shorten the life of the engine.

Engine oil level should be checked before every use.

1. Always operate or maintain the generator on a flat surface.
2. Stop engine if running.
3. Let engine sit and cool for several minutes (allow crankcase pressure to equalize).
4. With a damp rag, clean around the oil fill plug/dipstick.
5. Remove oil fill plug/dipstick (see Figure 15 below).

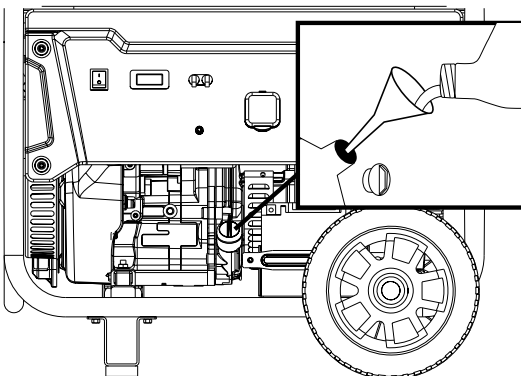

Figure 15 - Oil Fill Plug/Dipstick

6. Check oil level: When checking the engine oil, remove the oil fill plug/dipstick and wipe it clean. Thread the oil fill plug/dipstick all the way back in and then remove and check the oil level on the oil fill plug/dipstick.
 - **Acceptable Oil Level** – Oil is visible on the crosshatches between the H and L lines on the oil fill plug/dipstick (see Figure 16).
 - **Low Oil** – Oil is below the L line on the oil fill plug/ dipstick.

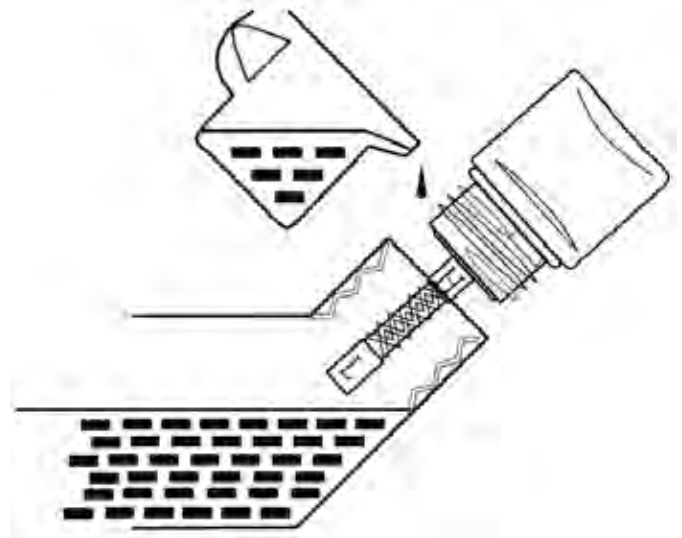

Figure 16 - Checking Oil Level

ADDING ENGINE OIL

1. Always operate or maintain the generator on a flat surface.
2. Stop engine if running.
3. Let engine sit and cool for several minutes (allow crankcase pressure to equalize).
4. Thoroughly clean around the oil fill plug/dipstick.
5. Remove oil fill plug/dipstick and wipe clean.
6. Select the proper engine oil as specified in Figure 14.
7. Using the supplied funnel and tube, slowly add engine oil to the engine. Stop frequently to check the level to avoid overfilling.
8. Continue to add oil until the oil is at the correct level (see Figure 16).

MAINTENANCE

CHANGING ENGINE OIL

1. Stop the engine.
2. Let engine sit and cool for several minutes (allow crankcase pressure to equalize).
3. Place oil pan (or suitable container) under the oil drain plug (see Figure 17).
4. With a damp rag, thoroughly clean around the oil drain plug.
5. Remove the oil drain plug (see Figure 17). Once removed, place the oil drain plug on a clean surface.

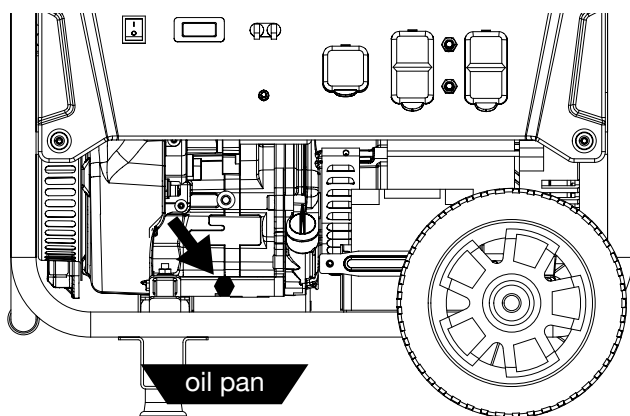

Figure 17 - Oil Drain Plug

6. Allow oil to completely drain.
7. Replace oil drain plug.
8. Fill crankcase with oil following the steps outlined in *Adding Engine Oil* on page 20.

NOTICE

Never dispose of used engine oil by dumping the oil into a sewer, on the ground, or into ground water or waterways. Always be environmentally responsible. Follow the guidelines of the EPA or other governmental agencies for proper disposal of hazardous materials. Consult local authorities or reclamation facility.

AIR FILTER MAINTENANCE

WARNING



Never use gasoline or other flammable solvents to clean the air filter. Use only household detergent soap to clean the air filter.

Cleaning the Air Filter

The air filter must be cleaned after every 50 hours of use or 3 months (frequency should be increased if generator is operated in a dusty environment).

1. Turn off the generator and let it cool for several minutes if running.
2. Move the generator to a flat, level surface.
3. Unclip the clips on the top and bottom of the air filter cover (Figure 18).

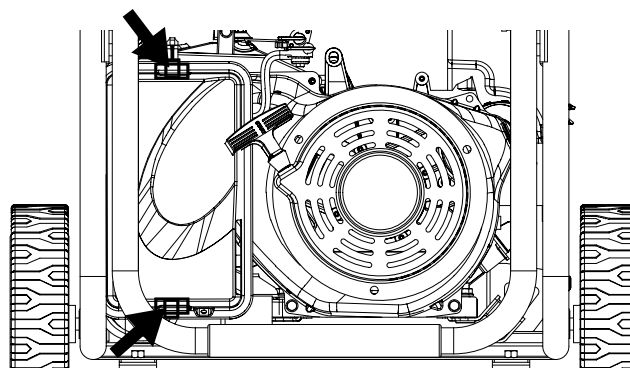

Figure 18 - Clips on air filter

4. Remove the black coarse air filters.
5. Wash the foam air filter elements by submerging the elements in a solution of household detergent soap and warm water. Slowly squeeze the foam to thoroughly clean.

NOTICE

NEVER twist or tear the foam air filter element during cleaning or drying. Only apply slow but firm squeezing action.

6. Rinse in clean water by submerging the air filter elements in fresh water and applying a slow squeezing action

MAINTENANCE

Cleaning the Air Filter - Continued from Page 21

NOTICE

Never dispose of soap cleaning solution used to clean the air filter by dumping the solution into a sewer, on the ground, or into ground water or waterways. Always be environmentally responsible. Follow the guidelines of the EPA or other governmental agencies for proper disposal of hazardous materials. Consult local authorities or reclamation facility.

1. Dispose of used soap cleaning solution properly.
2. Dry the air filter elements by again applying a slow firm squeezing action.
3. Once the air filters are dry, coat the air filters with clean engine oil (see Figure 19 below).



Figure 19

4. Squeeze the filters to remove any excess oil.
5. Install the filters back into the unit. If there are two filters make sure the gray (fine) air filter goes in first followed by the black (coarse) air filter on the outside.
6. Install the air filter cover and secure the air filter assembly.

SPARK PLUG MAINTENANCE

The spark plug must be checked and cleaned after every 100 hours of use or 6 months and must be replaced after 300 hours of use or every year.

1. Stop the generator and let it cool for several minutes if running.
2. Move the generator to a flat, level surface.
3. Remove the spark plug boot by firmly pulling the plastic spark plug boot handle directly away from the engine (see Figure 20).

NOTICE

Never apply any side load or move the spark plug laterally when removing the spark plug. Applying a side load or moving the spark plug laterally may crack and damage the spark plug boot.

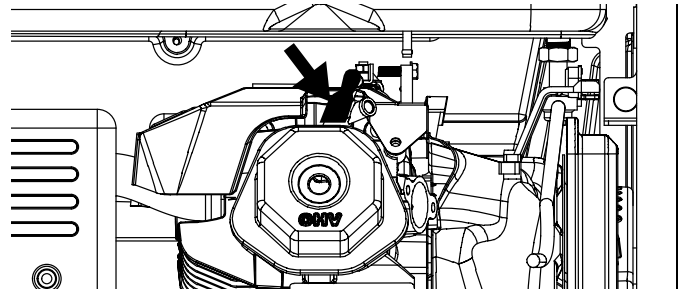

Figure 20 - Remove Spark Plug Boot

4. Clean area around the spark plug.
5. Using the 13/16" spark plug socket wrench provided, remove the spark plug from the cylinder head.
6. Place a clean rag over the opening created by the removal of the spark plug to make sure no dirt can get into the combustion chamber.

- Inspect the spark plug for:
 - Cracked or chipped insulator
 - Excessive wear
 - Spark plug gap (the acceptable limit of 0.027–0.032 in. [0.70 – 0.80 mm]) (see Figure 21).

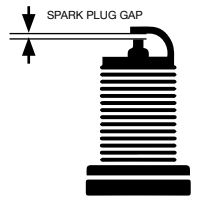

Figure 21

NOTICE

Use only recommended spark plugs when servicing. The manufacturer is not responsible for engine damage when using spark plugs not recommended by the manufacturer.

7. Install the spark plug by carefully following the steps outlined below:
 - a. Carefully insert the spark plug back into the cylinder head. Hand-thread the spark plug until it bottoms out.
 - b. Using the 13/16" spark plug socket wrench provided, turn the spark plug to ensure it is fully seated.
 - c. Replace the spark plug boot, making sure the boot fully engages the spark plug's tip.

Recommended Spark Plug Replacement:

AC Delco: 4EXLS
Autolite: 52
Champion: N9YC
Bosch: W7DC
Torch: F7TC

MAINTENANCE

CLEANING THE GENERATOR

It is important to inspect and clean the generator before every use.

Clean All Engine Air Inlet and Outlet Ports – Make sure all engine air inlet and outlet ports are clean of any dirt and debris to ensure the engine does not run hot.

Clean All Engine Cooling Fins – Use a damp rag and a brush to loosen and remove all dirt on or around the engine's cooling fins.

Clean All Alternator Cooling Air Inlets and Exhaust Ports – Make sure the cooling air inlets and exhaust ports of the alternator are free of any debris and obstructions. Use a vacuum cleaner to remove dirt and debris stuck in the cooling air inlets and exhaust ports.

General Cleaning of the Generator – Use a damp rag to clean all remaining surfaces.

STORING GENERATOR

⚠ WARNING



Never store a generator with fuel in the tank indoors or in a poorly ventilated area where the fumes can come in contact with an ignition source such as a: 1) pilot light of a stove, water heater, clothes dryer or any other gas appliance; or 2) spark from an electric appliance.

NOTICE

Gasoline stored for as little as 60 days can go bad, causing gum, varnish and corrosive buildup in fuel lines, fuel passages and the engine. This corrosive buildup restricts the flow of fuel, preventing an engine from starting after a prolonged storage period.

Proper care should be taken to prepare the generator for any storage.

1. Make sure the Engine Switch is switched to "STOP".
2. Clean the generator as outlined in *Cleaning the Generator*.
3. Drain all gasoline from the fuel tank as best as possible.
4. With the fuel shut off valve open, start the engine and allow the generator to run until all the remaining gasoline in the fuel lines and carburetor is consumed and the engine shuts off.

5. Close the fuel shut off valve.
6. Change the oil (see *Changing Engine Oil* on page 21).
7. Remove the spark plug (see *Spark Plug Maintenance* on page 22) and place about 1 tablespoon of oil in the spark plug opening. While placing a clean rag over the spark plug opening, slowly pull the coil handle to allow the engine to turn over several times. This will distribute the oil and protect the cylinder wall from corroding during storage.
8. Replace the spark plug (see *Spark Plug Maintenance* on page 22).
9. Move the generator to a clean, dry place for storage.

CHECKING AND ADJUSTING VALVE LASH

⚠ CAUTION



Checking and adjusting valve lash must be done when the engine is cold.

1. Remove the rocker arm cover and carefully remove the gasket. If the gasket is torn or damaged, it must be replaced.
2. Remove the spark plug so the engine can be rotated more easily.
3. Rotate the engine to top dead center (TDC) of the compression stroke. Looking through the spark plug hole, the piston should be at the top.
4. Both the rocker arms should be loose at TDC on the compression stroke. If they are not, rotate the engine 360°.
5. Insert a feeler gauge between the rocker arm and the push rod and check for clearance (see Figure 22). See Table 2 on page 24 for valve lash specifications.

MAINTENANCE

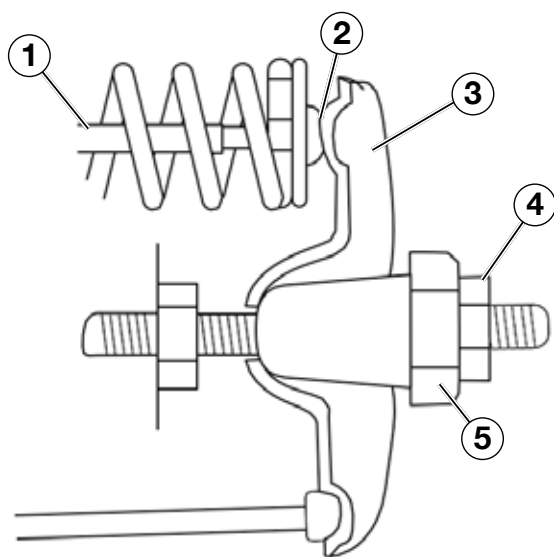

Figure 22
 (1) Push Rod, (2) Feeler Gauge Area
 (3) Rocker Arm, (4) Jam Nut, (5) Adjusting Nut

(Table 2) Standard Valve Lash

	Intake Valve	Exhaust Valve
Valve Lash	0.0035 ± 0.0043 in (0.09 ± 0.11 mm)	0.0043 ± 0.0051 in (0.11 ± 0.13 mm)
Bolt Torque	8-12N.m	8-12N.m

6. If an adjustment is required, hold the adjusting nut and loosen the jam nut.
7. Turn the adjusting nut to obtain the correct valve lash. When the valve lash is correct, hold the adjusting nut and tighten the jam nut to 106 in-lb (12 N•m).
8. Recheck the valve lash after tightening the jam nut.
9. Perform this procedure for both the intake and exhaust valves.
10. Install the rocker arm cover, gasket and spark plug.

TROUBLESHOOTING

⚠ WARNING



Before attempting to service or troubleshoot the generator, the owner or service technician must first read the owner's manual and understand and follow all safety instructions. Failure to follow all instructions may result in conditions that can lead to voiding of the EPA certification or product warranty, serious personal injury, property damage or even death.

PROBLEM	POTENTIAL CAUSE	SOLUTION
Engine is running, but no electrical output	1. Circuit breakers are tripped.	1. Reset the circuit breakers and check for overload condition.
	2. The power cord's plug connector is not fully engaged in the generator's outlet.	2. Verify plug connector is firmly engaged in the generator's outlet. If using the 240V outlet, make sure plug connector is rotated 1/4 turn in the clockwise direction.
	3. Faulty or defective power cord	3. Replace power cord.
	4. Faulty or defective electrical appliance	4. Try connecting a known good appliance to verify the generator is producing electrical power.
	5. GFCI outlet is tripped (units with GFCI outlets only)	5. Press the reset button on the GFCI outlet (GFCI outlets only).
	6. If trying 1-5 above does not solve the problem, the cause might be the generator has a fault.	6. Take the generator to your nearest authorized service dealer.

TROUBLESHOOTING

Engine will not start or remain running while trying to start.	1. Fuel shutoff valve is in the OFF position.	1. Move the fuel shut off valve to the ON position (see Figure 8 page 17).
	2. Generator is out of gasoline.	2. Add gasoline to the generator (see page 16).
	3. Fuel flow is obstructed.	3. Inspect and clean fuel delivery passages.
	4. Unit is over choked.	4. Move the choke lever halfway between the ON and OFF positions.
	5. Starting battery may have insufficient charge (electric start units only)	5. On electric start models only. Check battery output and charge battery as necessary.
	6. Dirty air filter	6. Check and clean the air filter (see page 21).
	7. Low oil level shut down switch is preventing the unit from starting.	7. Check oil level and add oil if necessary (see page 20).
	8. Spark plug boot is not fully engaged with the spark plug tip.	8. Firmly push down on the spark plug boot to ensure the boot is fully engaged
	9. Spark plug is faulty.	9. Remove and check the spark plug. Replace if faulty (see page 22).
	10. Dirty/plugged spark arrestor	10. Check and clean the spark arrestor.
	11. Stale fuel	11. Drain fuel and replace with fresh fuel (see page 17).
	12. If trying 1-11 above does not solve the problem, the cause might be the generator has a fault.	12. Take the generator to your nearest authorized service dealer.

PROBLEM	POTENTIAL CAUSE	SOLUTION
Generator suddenly stops running.	1. Generator is out of fuel.	1. Check fuel level (see page 16). Add fuel if necessary.
	2. The low oil shut down switch has stopped the engine.	2. Check oil level and add oil if necessary (see page 20).
	3. Too much load	3. Restart the generator and reduce the load.
	4. If trying 1-3 above does not solve the problem, the cause might be a fault in the generator.	4. Take the generator to your nearest authorized service dealer.

Engine runs erratic; does not hold a steady RPM.	1. Choke was left in the ON position.	1. Move choke to the OFF position
	2. Dirty air filter	2. Clean the air filter (see page 21).
	3. Applied loads maybe cycling on and off	3. As applied loads cycle, changes in engine speed may occur; this is a normal condition.
	4. If trying 1-3 above does not solve the problem, the cause might be a fault in the generator	4. Take the generator to your nearest authorized service dealer.

WGen2000 ENGINE VIEW

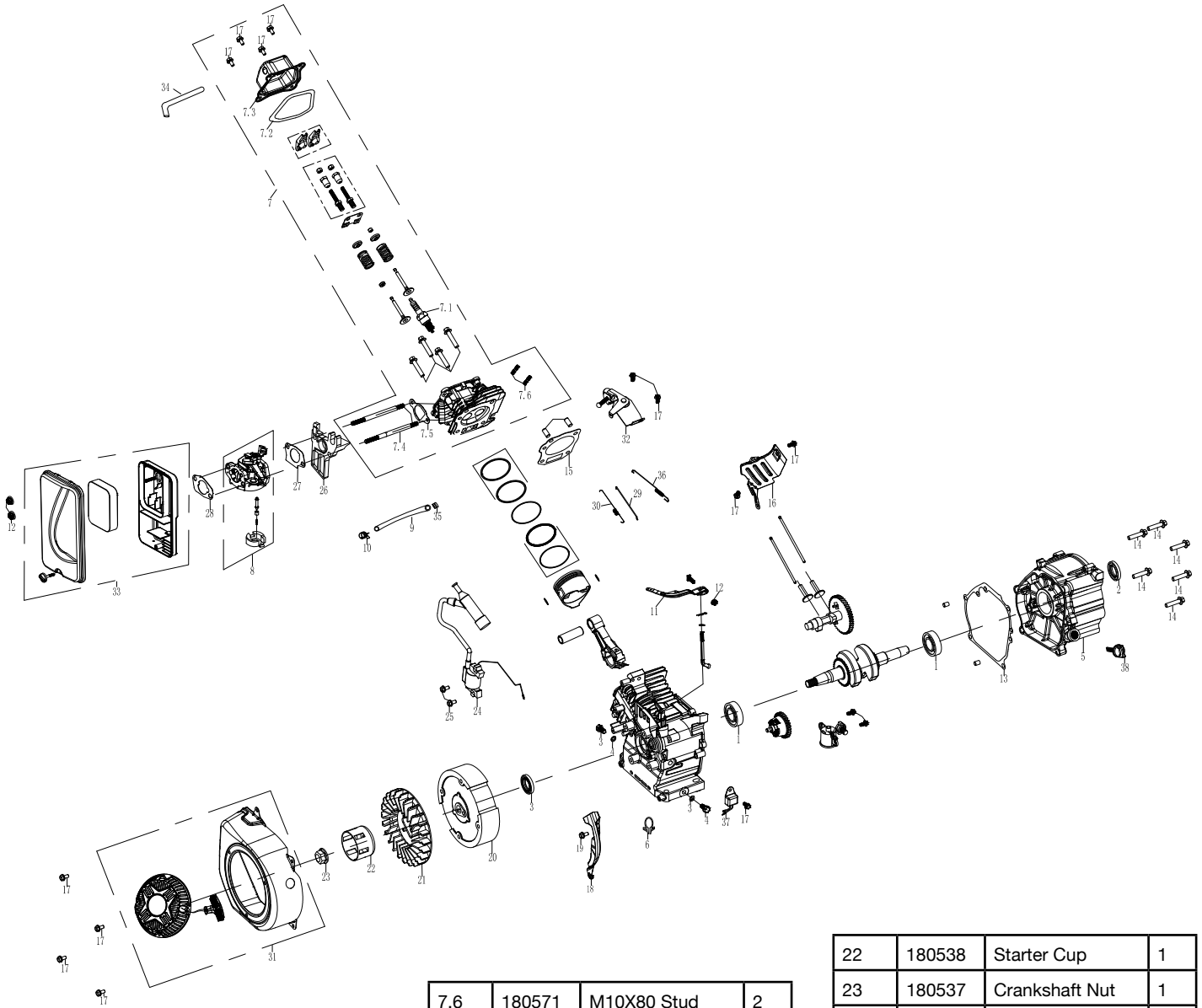

No.	Part.	Description	Qty
1	180556	Ball Bearing	2
2	180541	Oil Seal	2
3	180543	Drain Plug	2
4	180544	Drain Plug Seal	2
5	180546	Crankcase Cover	1
6	170502	Hose Clip	1
7	180548	Cylinder Head Assy	1
7.1	180526	Spark Plug	1
7.2	180555	Valve Cover Gasket	1
7.3	180554	Valve Cover	1
7.4	140515	M6 Stud	2
7.5	140516	Gasket	1

7.6	180571	M10X80 Stud	2
8	140512	Carburetor Assy	1
9	140518	Fuel Hose	1
10	140508	Hose Clamp	1
11	180549	Governor Arm	1
12	100548	M6 Nut	3
13	180545	Gasket	1
14	110503	M8X30	6
15	180547	Cylinder Head Gasket	1
16	180533	Heat Shield	1
17	120505	M6X12	13
18	180566	Dust Plate	1
19	180567	M6X20	1
20	180540	Flywheel Assy	1
21	180539	Engine Cooling Fan	1

22	180538	Starter Cup	1
23	180537	Crankshaft Nut	1
24	180542	Ignition Coil Assy	1
25	100518	M6X25	2
26	140514	Spacer	1
27	140513	Gasket	1
28	140517	Gasket	1
29	180570	Governor Linkage	1
30	180551	Throttle Return Spring	1
31	170501	Recoil Assy	1
32	180552	Governor Bracket	1
33	160501	Air Cleaner Assy	1
34	180559	Vent	1
35	140506	Fitting	1
36	180550	Governor Spring	1
37	180509	Amplifier	1
38	180557	Dipstick	1

WGen2000 EXPLODED VIEW

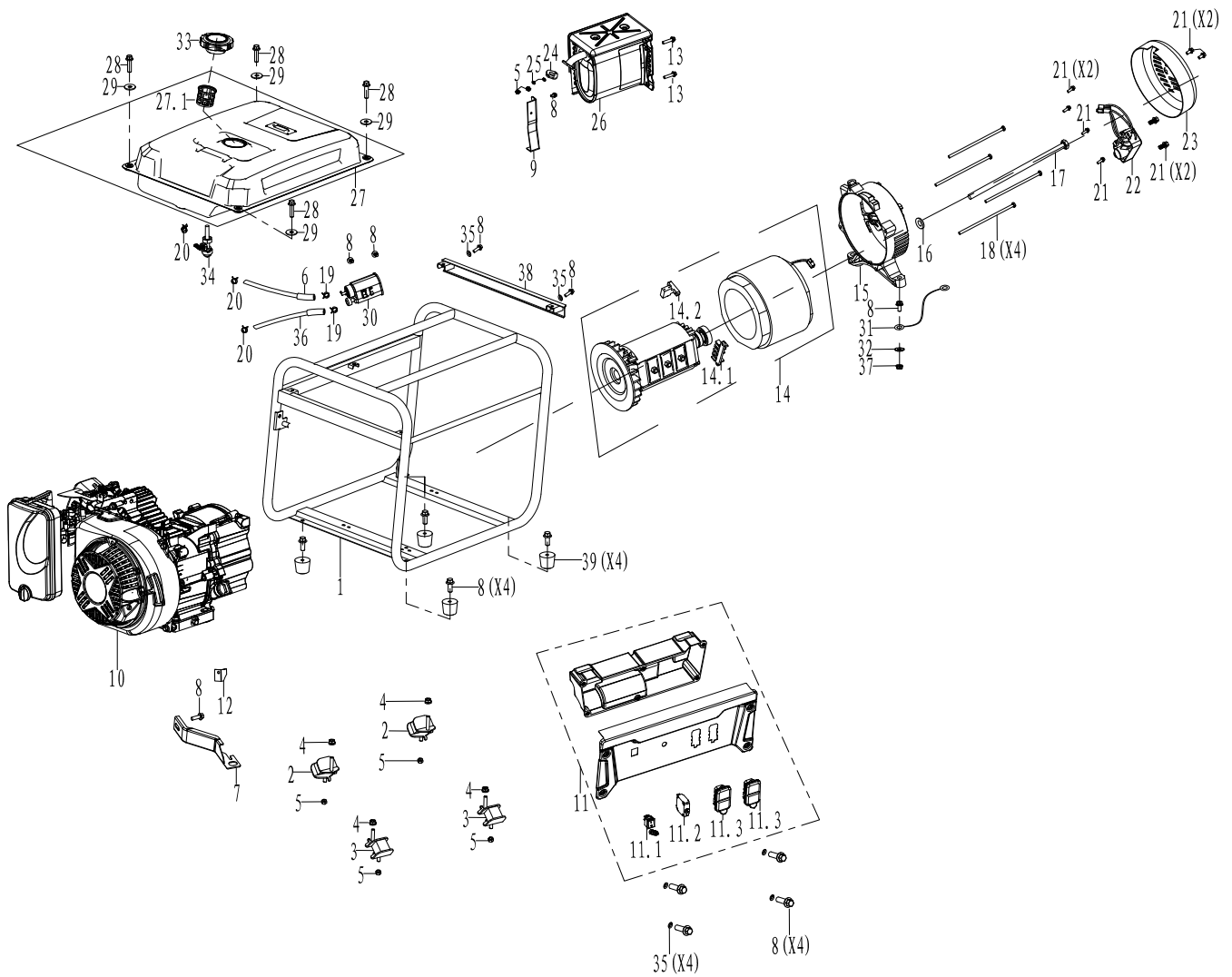

No.	Part.	Description	Qty
1	100550	Frame	1
2	105560	Damper	2
3	100559	Damper	2
4	100520	M8 Nut	4
5	180524	M8 Nut	6
6	150519	Hose	1
7	180569	Bracket	1
8	120505	M6X12	15
9	110520	Bracket	1
10	180565	Engine Assy	1
11	130520	Control Panel Assy	1
11.1	130502	Start Switch	1
11.2	130518	Circuit Breaker 1P18A	1
11.3	130512	R5-20 Receptacle	2
12	180568	Dust Plate	1
13	100516	M8X16	2
14	120538	Alternator Assy	1
14.1	120526	Terminal Block	1
14.2	120525	Brush Assy	1

15	120527	Rear Bearing Carrier	1
16	120532	Washer	1
17	100542	M8X185	1
18	120534	M6X130	4
19	150518	Hose Clamp	2
20	140508	Hose Clamp	3
21	120537	M5X12	8
22	120529	AVR	1
23	120530	Alternator Cover	1
24	110519	Gasket	1
25	110502	Spring Washer	2
26	110521	Muffler Assy	1
27	150521	Fuel Tank	1
27.1	150517	Fuel Strainer	1

28	120536	M6X25	4
29	150501	M6 Washer	4
30	150520	Carbon Canister	1
31	120528	Ground Strap	1
32	120533	M6 Washer	1
33	150505	Fuel Tank Cap	1
34	150502	Fuel Valve	1
35	100547	M6 Washer	6
36	150522	Hose	1
37	100548	M6 Nut	1
38	100530	Bracket	1
39	100549	Rubber Foot	4

WGen3600 ENGINE VIEW

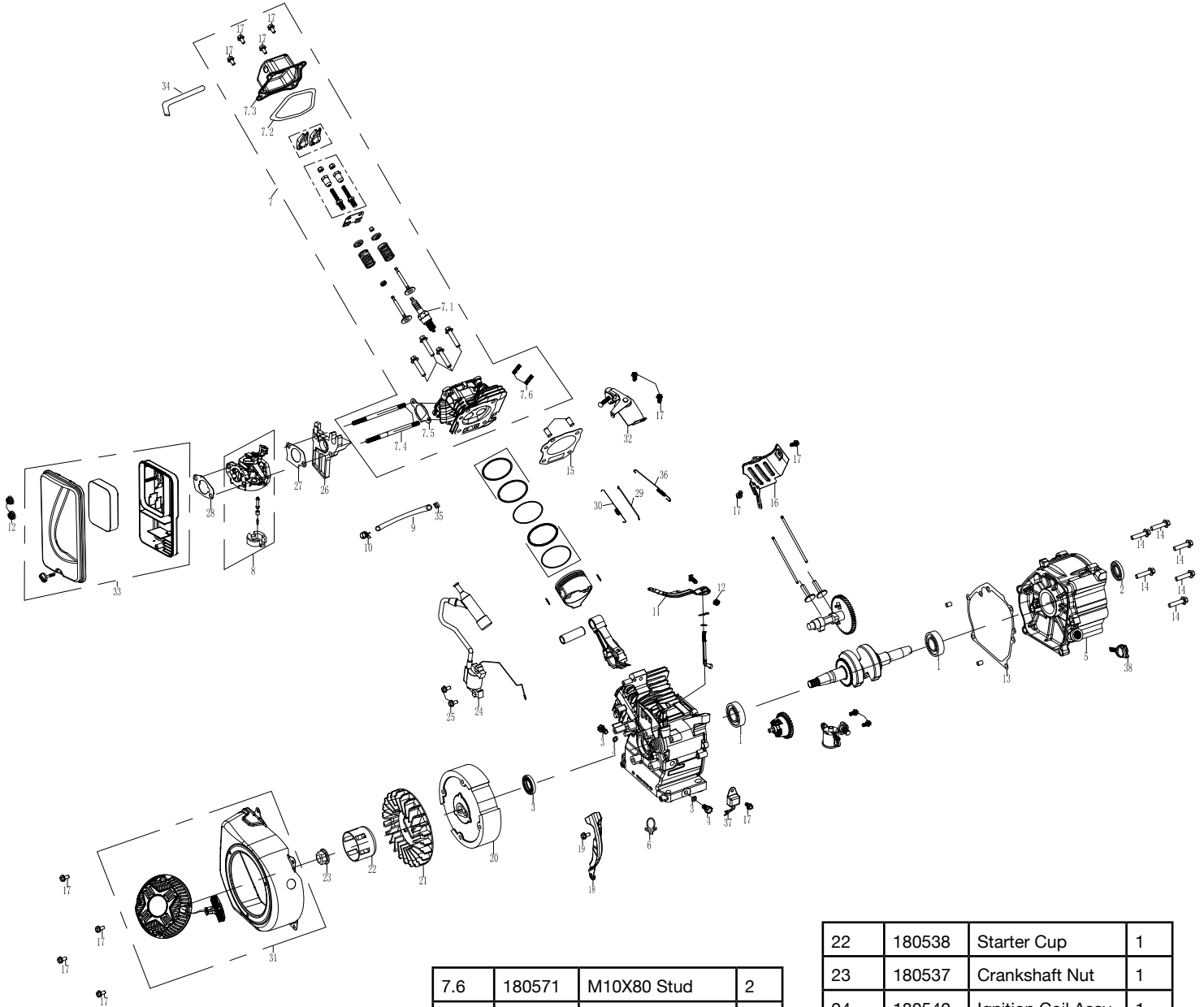

No.	Part.	Description	Qty
1	180556	Ball Bearing	2
2	180541	Oil Seal	2
3	180543	Drain Plug	2
4	180544	Drain Plug Seal	2
5	180546	Crankcase Cover	1
6	170502	Hose Clip	1
7	180548	Cylinder Head Assy	1
7.1	180526	Spark Plug	1
7.2	180555	Valve Cover Gasket	1
7.3	180554	Valve Cover	1
7.4	140515	M6 Stud	2
7.5	140516	Gasket	1

7.6	180571	M10X80 Stud	2
8	140512	Carburetor Assy	1
9	140518	Fuel Hose	1
10	140508	Hose Clamp	1
11	180549	Governor Arm	1
12	100548	M6 Nut	3
13	180545	Gasket	1
14	110503	M8X30	6
15	180547	Cylinder Head Gasket	1
16	180533	Heat Shield	1
17	120505	M6X12	13
18	180566	Dust Plate	1
19	180567	M6X20	1
20	180540	Flywheel Assy	1
21	180539	Engine Cooling Fan	1

22	180538	Starter Cup	1
23	180537	Crankshaft Nut	1
24	180542	Ignition Coil Assy	1
25	100518	M6X25	2
26	140514	Spacer	1
27	140513	Gasket	1
28	140517	Gasket	1
29	180570	Governor Linkage	1
30	180551	Throttle Return Spring	1
31	170501	Recoil Assy	1
32	180552	Governor Bracket	1
33	160501	Air Cleaner Assy	1
34	180559	Vent	1
35	140506	Fitting	1
36	180550	Governor Spring	1
37	180509	Amplifier	1
38	180557	Dipstick	1

WGen3600 EXPLODED VIEW

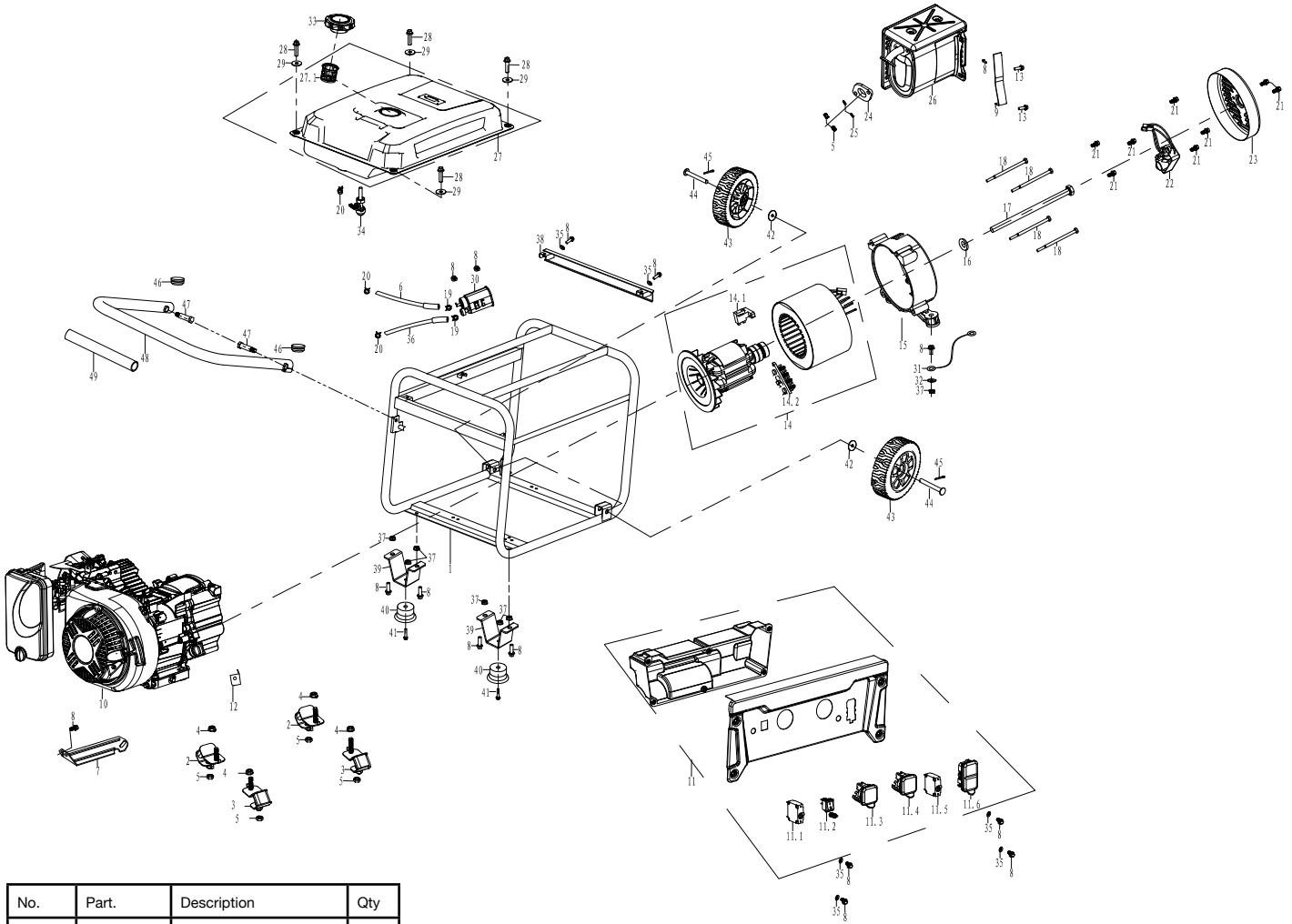

No.	Part.	Description	Qty
1	100536	Frame	1
2	105560	Damper	2
3	100559	Damper	2
4	100520	M8 Nut	4
5	180524	M8 Nut	6
6	150519	Hose	1
7	180569	Bracket	1
8	120505	M6X12	15
9	110520	Bracket	1
10	180565	Engine Assy	1
11	130519	Control Panel Assy	1
11.1	130509	Circuit Breaker 1P30A	1
11.2	130502	Start Switch	1
11.3	130510	L5-30 Receptacle	1
11.4	130511	TT-30 Receptacle	1
11.5	130507	Circuit Breaker 1P20A	1
11.6	130512	R5-20 Receptacle	1
12	180568	Dust Plate	1
13	100516	M8X16	2
14	120524	Alternator Assy	1
14.1	120525	Brush Assy	1
14.2	120526	Terminal Block	1
15	120527	Rear Bearing Carrier	1
16	120532	Washer	1

17	120531	M8X220	1
18	120521	M6X165	4
19	150518	Hose Clamp	2
20	140508	Hose Clamp	3
21	120537	M5X12	8
22	120529	AVR	1
23	120530	Alternator Cover	1
24	110519	Gasket	1
25	110502	Spring Washer	2
26	110518	Muffler Assy	1
27	150521	Fuel Tank	1
27.1	150517	Fuel Strainer	1
28	120536	M6X25	4
29	150501	M6 Washer	4
30	150520	Carbon Canister	1
31	120528	Ground Strap	1
32	120508	M6 Tooth Washer	1

33	150505	Fuel Tank Cap	1
34	150502	Fuel Valve	1
35	100547	Washer	6
36	150522	Hose	1
37	100548	M6 Nut	7
38	100530	Bracket	1
39	100541	Foot Bracket	2
40	100515	Rubber Pad	2
41	100518	M6X25	2
42	100540	Washer	2
43	100538	Wheel	2
44	100537	Axle Pin	2
45	100508	Cotter Pin	2
46	100546	Plug	2
47	100545	Handle Fastener	2
48	100543	Handle	1
49	100544	Handle Cover	1

WGen3600v ENGINE VIEW

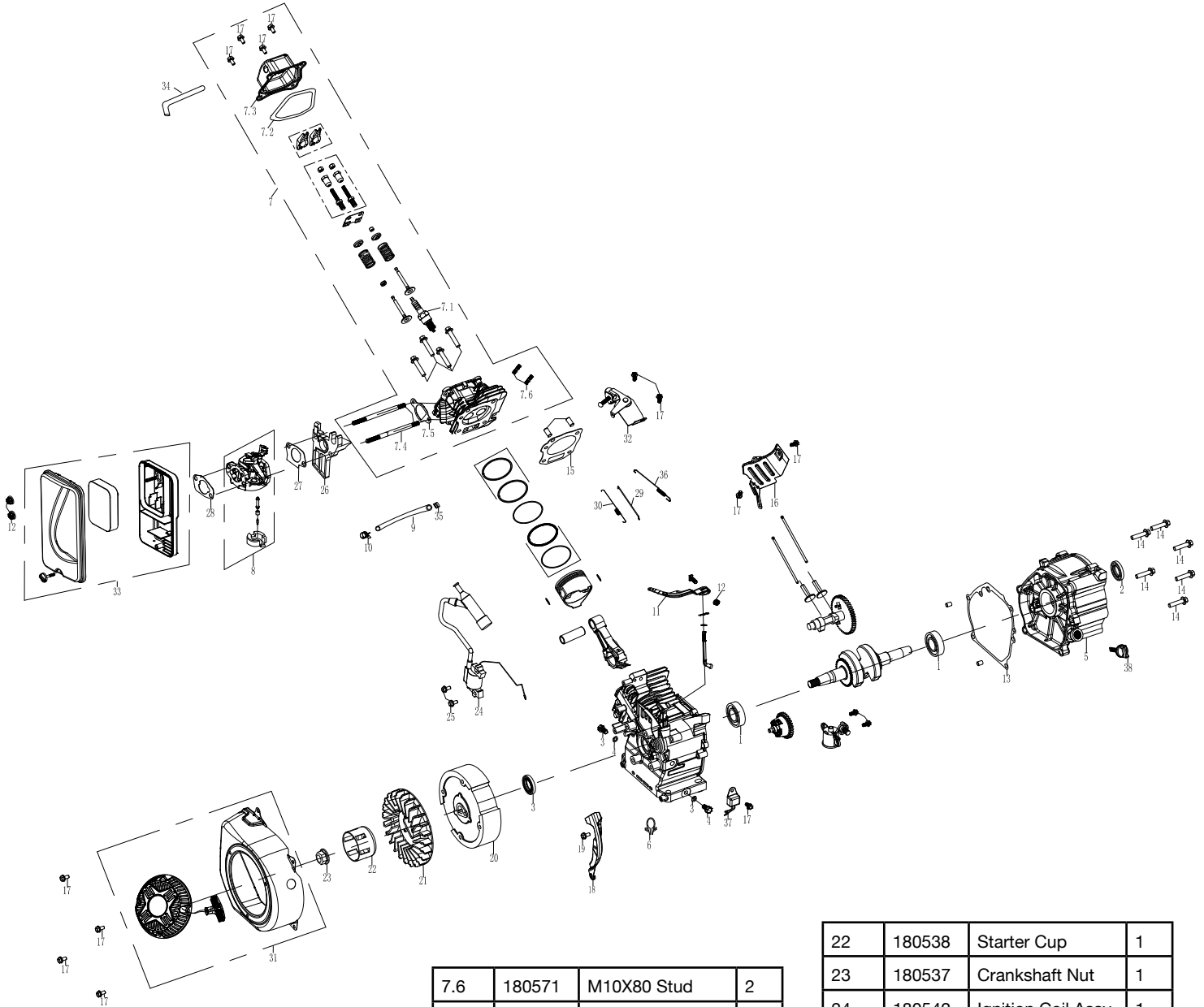

No.	Part.	Description	Qty
1	180556	Ball Bearing	2
2	180541	Oil Seal	2
3	180543	Drain Plug	2
4	180544	Drain Plug Seal	2
5	180546	Crankcase Cover	1
6	170502	Hose Clip	1
7	180548	Cylinder Head Assy	1
7.1	180526	Spark Plug	1
7.2	180555	Valve Cover Gasket	1
7.3	180554	Valve Cover	1
7.4	140515	M6 Stud	2
7.5	140516	Gasket	1

7.6	180571	M10X80 Stud	2
8	140512	Carburetor Assy	1
9	140518	Fuel Hose	1
10	140508	Hose Clamp	1
11	180549	Governor Arm	1
12	100548	M6 Nut	3
13	180545	Gasket	1
14	110503	M8X30	6
15	180547	Cylinder Head Gasket	1
16	180533	Heat Shield	1
17	120505	M6X12	13
18	180566	Dust Plate	1
19	180567	M6X20	1
20	180540	Flywheel Assy	1
21	180539	Engine Cooling Fan	1

22	180538	Starter Cup	1
23	180537	Crankshaft Nut	1
24	180542	Ignition Coil Assy	1
25	100518	M6X25	2
26	140514	Spacer	1
27	140513	Gasket	1
28	140517	Gasket	1
29	180570	Governor Linkage	1
30	180551	Throttle Return Spring	1
31	170501	Recoil Assy	1
32	180552	Governor Bracket	1
33	160501	Air Cleaner Assy	1
34	180559	Vent	1
35	140506	Fitting	1
36	180550	Governor Spring	1
37	180509	Amplifier	1
38	180557	Dipstick	1

WGen3600v EXPLODED VIEW

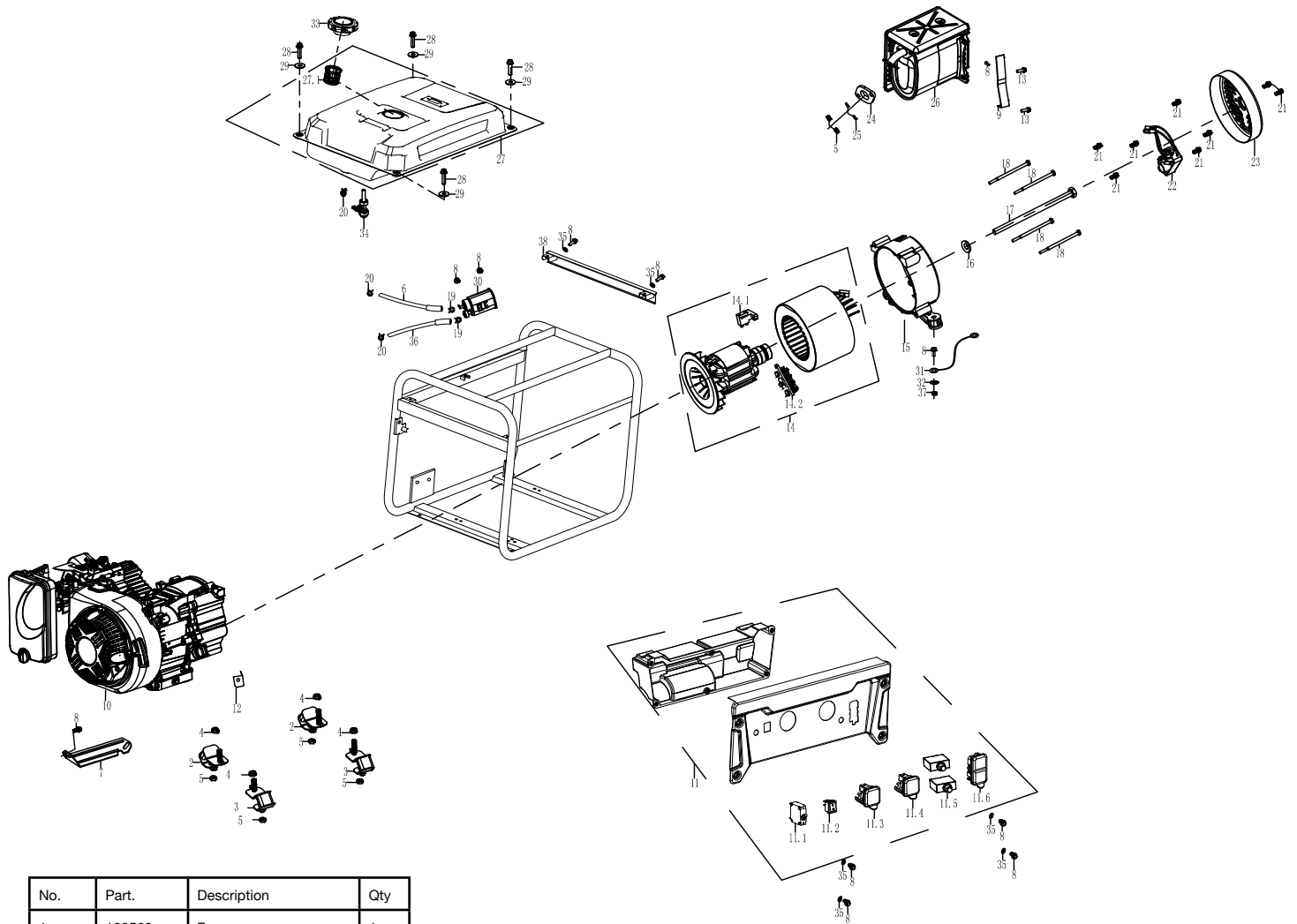

No.	Part.	Description	Qty
1	100560	Frame	1
2	105560	Damper	2
3	100559	Damper	2
4	100520	M8 Nut	4
5	180524	M8 Nut	4
6	150519	Hose	1
7	180569	Bracket	1
8	120505	M6X12	15
9	110520	Bracket	1
10	180565	Engine Assy	1
11	130519	Control Panel Assy	1
11.1	130509	Circuit Breaker 1P30A	1
11.2	130502	Start Switch	1
11.3	130510	L5-30 Receptacle	1
11.4	130511	TT-30 Receptacle	1
11.5	130524	Circuit Breaker 1P20A	1
11.6	130512	R5-20 Receptacle	1
12	180568	Dust Plate	1
13	100516	M8X16	2
14	120524	Alternator Assy	1
14.1	120525	Brush Assy	1
14.2	120526	Terminal Block	1

15	120527	Rear Bearing Carrier	1
16	120532	Washer	1
17	120531	M8X220	1
18	120521	M6X165	4
19	150518	Hose Clamp	2
20	140508	Hose Clamp	3
21	120537	M5X12	8
22	120529	AVR	1
23	120530	Alternator Cover	1
24	110519	Gasket	1
25	110502	Spring Washer	2
26	110518	Muffler Assy	1
27	150521	Fuel Tank	1
27.1	150517	Fuel Strainer	1
28	120536	M6X25	4
29	150501	M6 Washer	4
30	150520	Carbon Canister	1

31	120528	Ground Strap	1
32	120508	M6 Tooth Washer	1
33	150505	Fuel Tank Cap	1
34	150502	Fuel Valve	1
35	100547	Washer	6
36	150522	Hose	1
37	100548	M6 Nut	7
38	100530	Bracket	1

WGen3600/WGen3600v SCHEMATIC

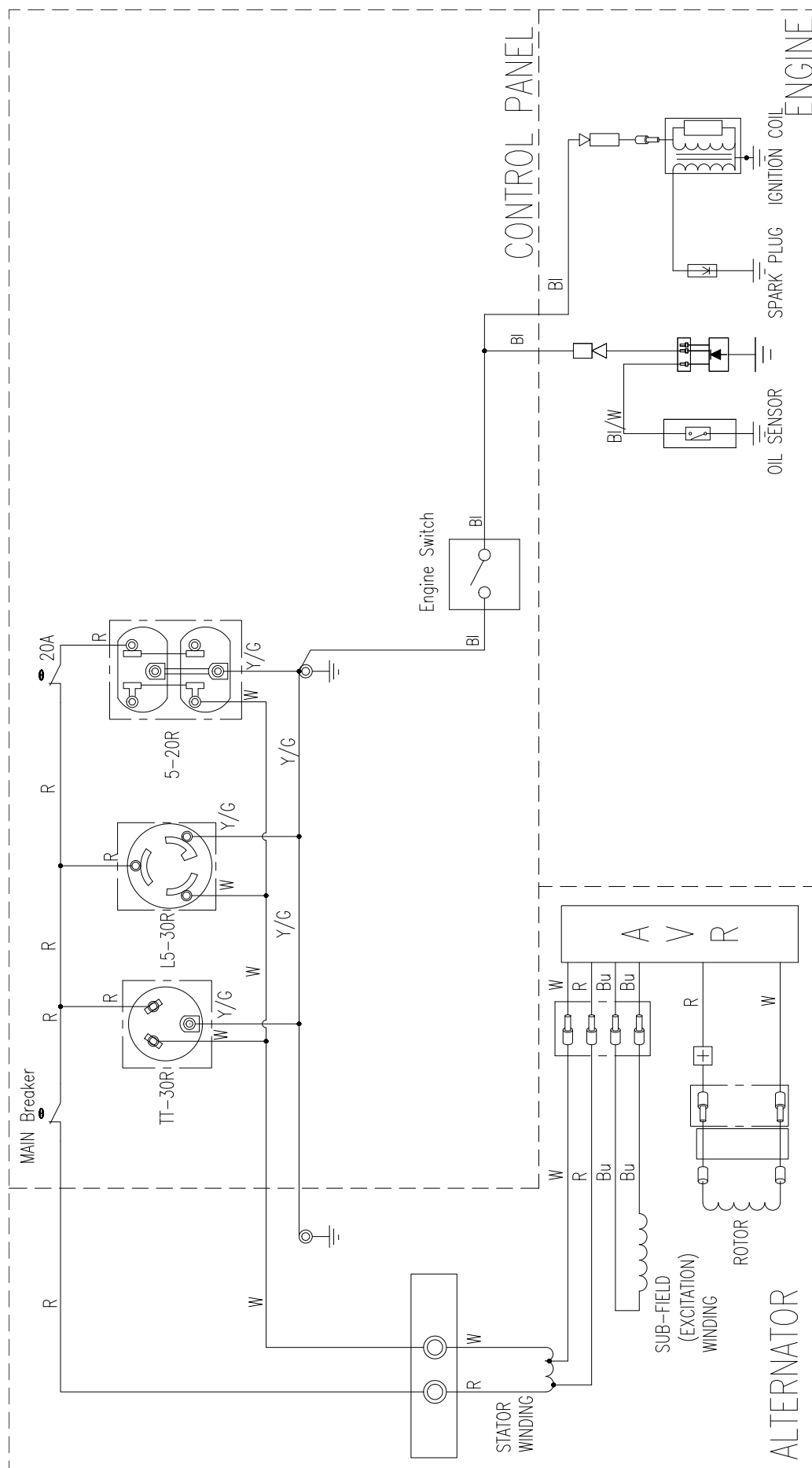

WGen2000 SCHEMATIC

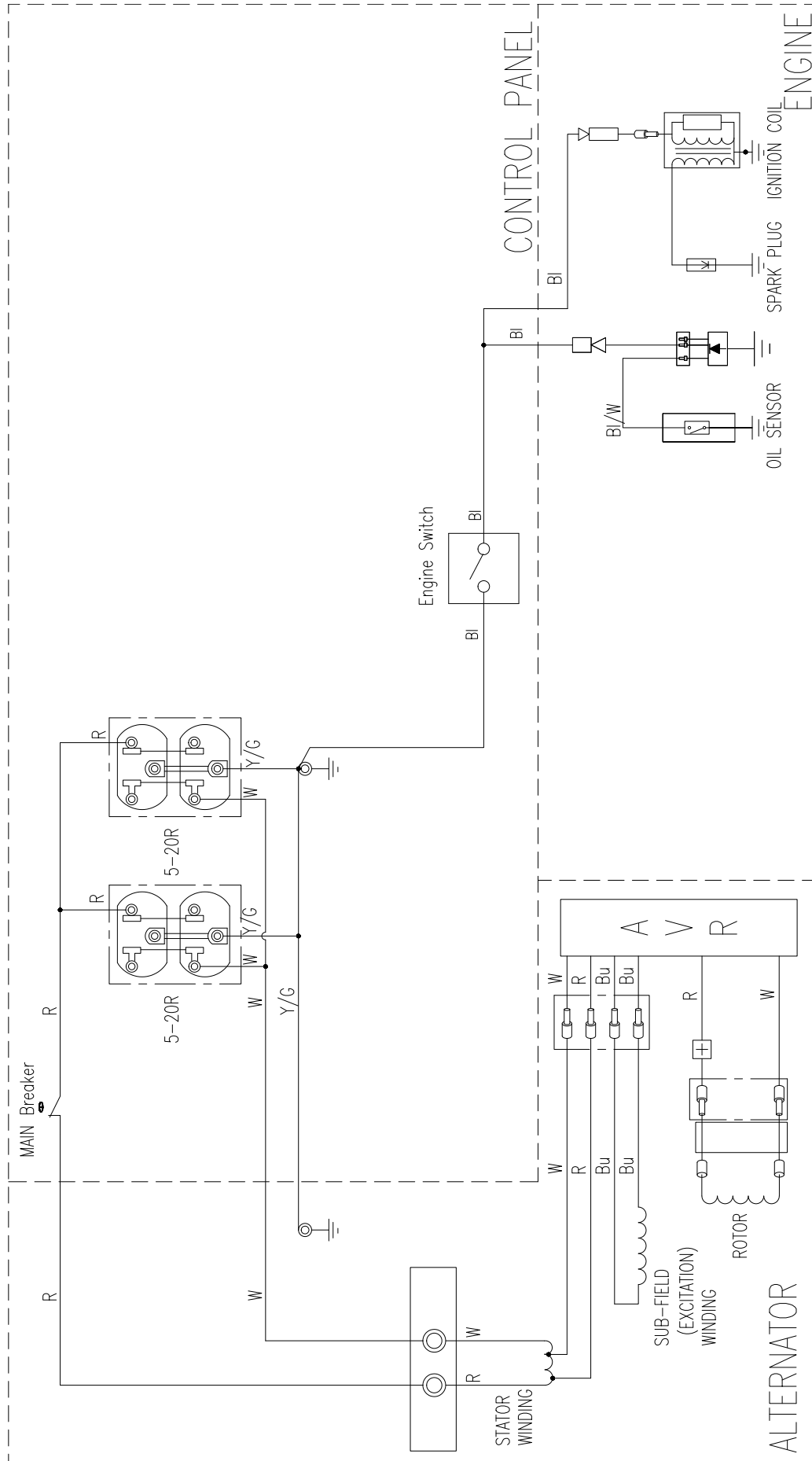

Maintenance Notes



WestinghousePortablePower.com

Service Hotline: (855) 944-3571

**777 Manor Park Drive
Columbus, OH 43228**

™ & © 2016 Westinghouse Electric Corporation
© 2016 MWE Investments, LLC. All Rights Reserved.

Version 7.11.17KD